

Motor Vehicle Registry Information Bulletin

L11 - Heavy Vehicle Driver's Information

Class LR, MR, HR, HC and MC

Effective Date: 17 December 2008

Before you can be considered for a Heavy Vehicle Driver Licence or an upgrade to your existing licence, you will need to satisfy certain prerequisites as follows below. Information contained at the last page of this bulletin may assist you in deciding which class of licence would best suit your needs.

Licence Prerequisites

Class "LR" (Light Rigid) –

Before an application for a class "LR" may be considered, the applicant must:

- reside in the Northern Territory;
- have held a licence to drive a car (class "C") for a period not less than 12 months, and hold an open (not provisional) driver licence.
- pass the required practical test (theory test is not required), or complete an approved training course.

Class "MR" (Medium Rigid) –

Before an application for a class "MR" may be considered, the applicant must:

- reside in the Northern Territory;
- have held a licence to drive a car (class "C") for a period not less than 12 months, and hold an open (not provisional) driver licence.
- pass the required theory and practical test - or complete an approved training course.

Class "HR" (Heavy Rigid) –

Before an application for a class "HR" may be considered, the applicant must:

- reside in the Northern Territory;
- have held a licence to drive a car (class "C") for periods totalling 24 months, 12 months of which must have been continuous, and hold an open (not provisional) driver licence;
- pass the required theory and practical test - or complete an approved training course. Please note that holders of a class "MR" driver licence will have already passed the theory test.

Class "HC" (Heavy Combination) –

Before an application for a class "HC" may be considered, the applicant must:

- reside in the Northern Territory;
- have held for a period or periods totalling not less than 12 months a licence to drive a class "MR" or "HR" vehicle;
- pass the required practical test - or complete an approved training course.

Class “MC” (Multi Combination) –

Before an application for a class “MC” may be considered, the applicant must:

- reside in the Northern Territory;
- have held for a period or periods totalling not less than 12 months a licence to drive a vehicle in either class “HR” or “HC”;
- pass the required practical test - or complete an approved training course.

Classifications for Specific “Unusual” Vehicle Combinations

In some situations, a higher class of licence **may not be required** when an applicant wishes to drive only one **specific** “unusual” vehicle combination. In most cases, appropriate conditions can be added to the existing licence, reducing the inconvenience and expense of going through extra training.

If you believe that you may be eligible for this consideration, enquiries should be directed to the Driver Licensing Operations Coordinator on:

MVR Hotline: 1300 654 628

Heavy Vehicle Licence Classes

Class “LR” (Light Rigid)

A motor vehicle that has a GVM greater than 4.5 tonnes, but not greater than 8 tonnes, **or** is constructed or equipped to seat more than 12 adults (including the driver).

Class “MR” (Medium Rigid)

A rigid motor vehicle which has 2 axles and a GVM greater than 8 tonnes.

IMPORTANT NOTE:

Drivers with “MR” licenses may only tow a pig trailer that must weigh less than 9 tonnes GVM and comply with the manufacturer’s Gross Combination Mass (GCM) limit for the towing vehicle.

Class “HR” (Heavy Rigid)

A rigid motor vehicle or an articulated motor omnibus which has 3 or more axles and a GVM greater than 8 tonnes.

Important Note:

Drivers with “HR” licenses may only tow a pig trailer that must weigh less than 9 tonnes GVM and comply with the manufacturer’s Gross Combination Mass (GCM) limit for the towing vehicle.

For practical test purposes, the vehicle you provide for your test must be at least 15 tonnes GVM, and have a minimum of 3 axles.

Class “HC” (Heavy Combination)

A motor vehicle that is a prime mover, to which is attached a single semi trailer that has a GVM greater than 9 tonnes, plus any unladen converter dolly.

OR

A rigid motor vehicle, to which is attached a trailer that has a GVM greater than 9 tonnes, plus any unladen converter dolly.

For practical test purposes, the vehicle that you provide for your test must be either:

- a 3 axled prime mover towing at least a 2 axled semi trailer, or
- at least a 3 axled rigid vehicle of more than 15 tonnes GVM towing a trailer of more than 9 tonnes GVM.

Class “MC” (Multi-Combination)

Any motor vehicle or combination of motor vehicles other than a motor bike or motor trike.

For practical test purposes, the vehicle which you supply for your practical test must be either:

- a 3 axled prime mover towing at least a 2 axled semi trailer, plus 1 extra trailer where the GVM is greater than 9 tonnes, or
- at least a 3 axled rigid vehicle where the GVM is greater than 15 tonnes towing 2 trailers, both of which have a GVM greater than 9 tonnes.

Buses Used for Hire or Reward

Appropriately licensed drivers may drive buses, which fit into the above categories. However **passengers can only be carried for Hire or Reward if the holder has an (h) endorsement.**

For further details, see MVR Information Bulletin CPV05 – How to obtain a Hire or Reward (h) Endorsement.

Upgrading Your Licence

Applicants wishing to upgrade their licence to any of the heavy vehicle licence classifications may learn to drive the desired vehicle, providing that:

1. They have passed the heavy vehicle theory test.
2. They have satisfied the prerequisites for the licence for which you are applying – **excluding the practical test.**

Note: If applying to upgrade to a Class “LR” licence, the theory test is not required.

Please note that you may only drive a heavier classification vehicle with an appropriately licensed person occupying the seat next to the driver, or in the case of buses, the seat nearest the driver, and must display an approved “Driver Under Instruction” sign at the rear of the vehicle. The sign must be yellow and no smaller than 530mm wide and 300mm high, with black writing at least 75mm high.

Practical tests may take up to 2 hours depending on the class of licence sought, and applicants are required to drive in a safe, legal, proficient and professional manner throughout.

Training

Australia and overseas experience shows that proper training of truck drivers significantly reduces maintenance costs (by almost 50% in some instances), improves fuel economy, and can help improve safe driving practices.

It is not feasible to cover every aspect of the knowledge and skills required to drive a truck, or the conditions under which you will drive, in the theory and practical tests available through Motor Vehicle Registry offices or Police Stations. For this reason, and to improve employment prospects, we recommend the thoroughness of professional training that is available through local driving schools and/or through Registered Training Organisations that deliver certain approved training programs.

Recommended Reading

The recommended reading material (listed) does not cover specialist knowledge or techniques needed for driving other classes of heavy vehicles such as buses, coaches, graders or tractors. It also does not replace the driving handbooks provided in each state which detail their road laws and driving requirements.

- The [Motor Vehicle \(Standards\) Regulations](#) – available for purchase from NT Government Publications.
- **Load Restraint Guide** – available for purchase from Motor Vehicle Registry offices or from the National Transport Commission via the web: www.ntc.gov.au .

The following pages contain information that may be asked in the Heavy Vehicle Theory Test.

Information that may be asked in the Heavy Vehicle Theory Test

All drivers of vehicles with a GVM greater than 15 tonnes must carry their driver licence and have zero blood alcohol concentration.

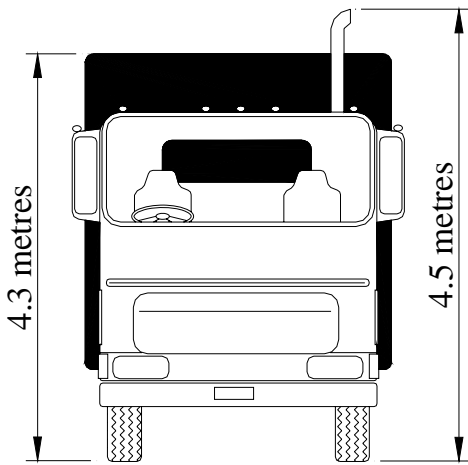

Height of Vehicles

Height of vehicle and its load to be no greater than 4.3 metres, except for cattle crates and car carriers, which must not exceed 4.6 metres.

Vertical exhaust stacks are not to exceed 4.5 metres.

Mirrors

On all vehicles mirrors may protrude no more than 150mm beyond the maximum permitted width of the vehicle.

Vehicles over 8.5 tonnes GVM may have mirrors which protrude to 230mm provided they are capable of retracting to less than 150mm of the maximum permitted width of the vehicle.

Width of Vehicles

The maximum width of a vehicle (not including retractable mirrors) and its load shall not exceed 2.5 metres.

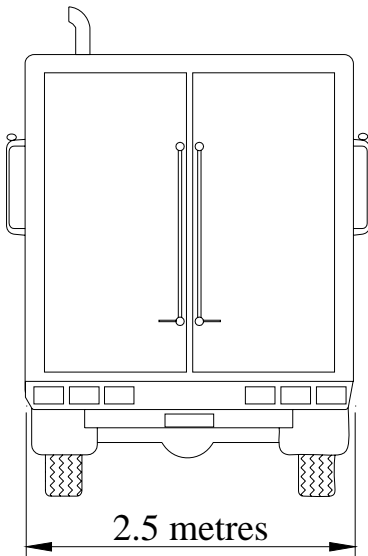

Length of Vehicles

The maximum length of a rigid motor vehicle must not exceed 12.5 metres.

The maximum length of an articulated or rigid motor vehicle and trailer combination other than a Road Train must not exceed 19 metres.

The maximum length of a Road Train is 53.5 metres.

Tyres Wheels and Axle Load Limits for Common Standard Configurations

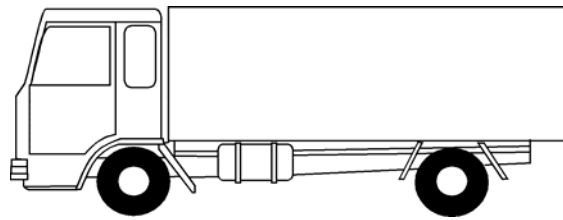

6 tonnes

9 tonnes dual wheels or
6 tonnes single

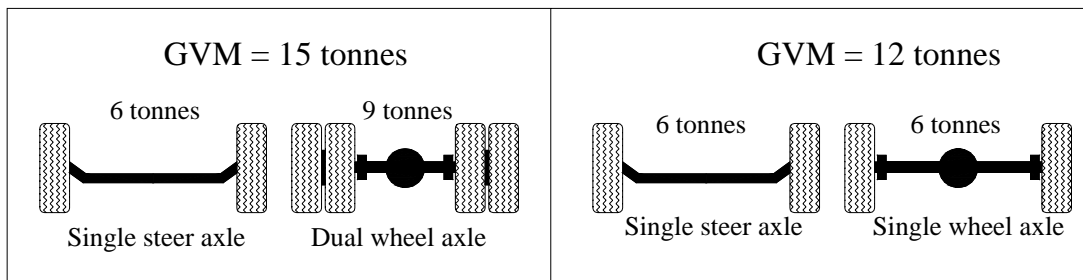

Axle Loads as per Motor Vehicle (Standards) Regulations

Refer to [Motor Vehicle \(Standards\) Regulations](#)

Important Note: This may be subject to change from time to time. Please check the *Motor Vehicle (Standards) Regulations* (see website address above) for the latest, up to date information.

Single Steer Axle		6.0 tonnes
Single Axle Group	2 tyres	6.0 tonnes
	4 tyres	9.0 tonnes
Twin Steer		
Load sharing		11.0 tonnes
Non load sharing		10.0 tonnes
Tandem Axle Groups		
Load Sharing	8 tyres	16.5 tonnes
	6 tyres	13.0 tonnes
	4 tyres	11.0 tonnes
Triaxle Groups		
Load sharing	12 tyres	20.0 tonnes
	6 tyres	15.0 tonnes

Gross Vehicle Mass (GVM)

Definition: The maximum laden mass at which a vehicle should be operated. This means the mass of the vehicle, plus the mass of the load.

Gross Combination Mass (GCM)

Definition: The maximum laden mass which the vehicle, in combination with one or more trailers attached to it should carry or tow.

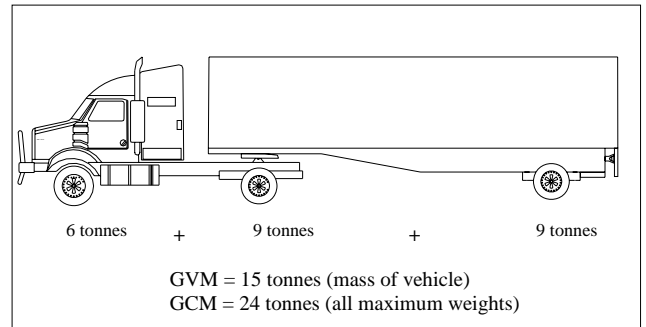
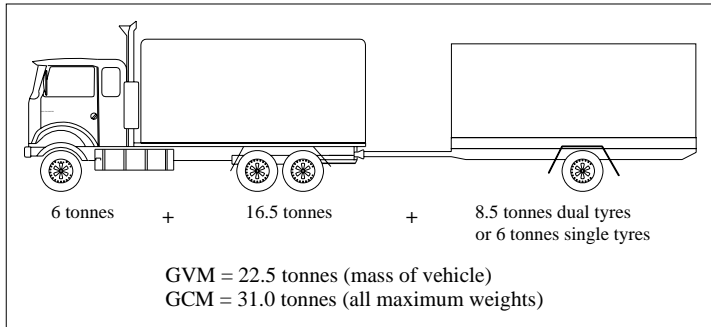

The maximum permitted GVM and GCM for vehicles shall be the lowest of:

- the manufacturer's rating;
- the sum of the permitted tyre, axle or axle group loads.
- the mass recorded by the Registrar

This information may originate from either:

- (a) the Compliance Plate of the vehicle;
- (b) a letter on Company letterhead from the vehicle manufacturer;

If neither of the above are available, the vehicle will be rated in accordance with Schedule 3 of the [Motor Vehicle \(Standards\) Regulations](#)

GVM and GCM Labels

Refer to [Motor Vehicle \(Standards\) Regulations](#)

These labels are applied to the windscreen or left quarter vent of vehicles over 4.5 tonnes GVM at the time of registration, and may only be applied by a Transport Inspector.

GVM = Gross Vehicle Mass
GCM = Gross Combination Mass



GVM rating label is placed above the GCM rating label and is applicable to the rigid vehicle or hauling unit only.

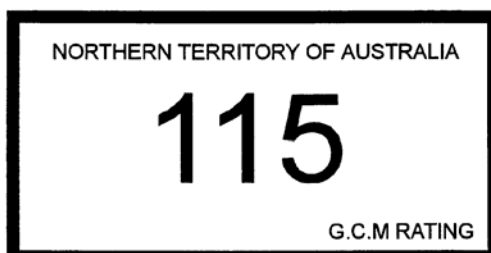

GCM is the combined maximum laden mass of the hauling unit and trailers.

Examples of Vehicle Mass

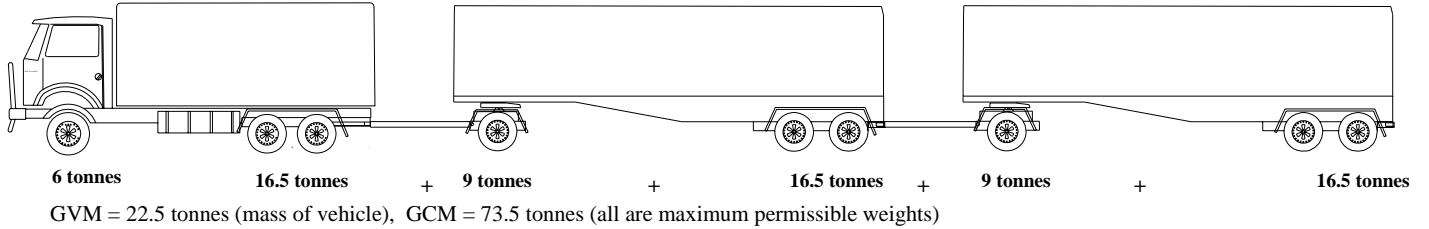
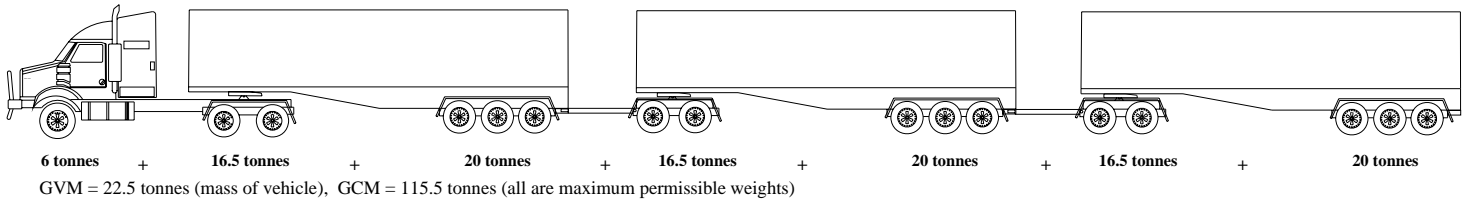

Load Restraint & Projecting Loads

Refer to [Traffic Regulations](#)

A person shall not drive a vehicle on a public street if the load is not secured in a manner described in the Load Restraint Guide published by the Department of Transport and Regional Services. Responsibility rests with the driver to ensure that the load carried is adequately secured.

Responsibility rests with the driver to ensure that the load carried is within the prescribed limits.

Maximum Distance of Projecting Load

The maximum distance that a load may project from the front or rear of any vehicle should not exceed 1.2 metres.

If the rear projection is in excess of 1.2 metres, a brightly coloured flag, or piece of material, with each side at least 300mm x 300mm, must be displayed at the extremity of the projection (keep in mind that the projection must be contained within legal rear overhang).

The overall permissible length of a rigid vehicle and its load shall not exceed 12.5 metres. Under certain circumstances permits of exemption from the above requirements may be granted. See the picture below for dimensions and how the overhang is calculated.

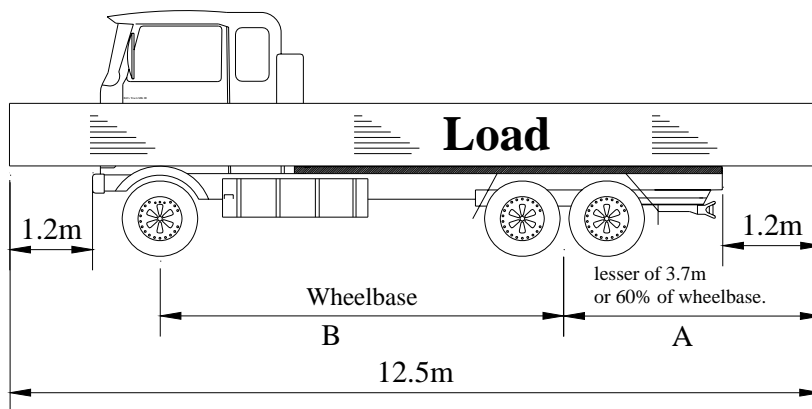

'A' shall not exceed 3.7 m, or 60 % of 'B', whichever is lesser

RIGID MOTOR VEHICLE

Lights on a Projecting Load

Between sunset and sunrise, a person driving a vehicle with a load projecting more than 1.2 metres behind the vehicle must attach a red lamp or not less than 2 red reflectors to the rear of the projecting load so that the load is clearly visible.

Warning Signals & Safety Equipment

Refer to [Traffic Regulations](#)

In the event of a breakdown on a public road, at night or within 100m of a curve, crest or obstruction, or where a load or part load falls from a vehicle onto the roadway, the operator shall place at least 3 reflective warning triangles positioned at the front, rear and side of the vehicle so as to give any approaching driver adequate warning.

The warning triangles shall remain in place as long as the vehicle is stationary and under emergency situations, the operator may assist in the delineation of safe passage for other motorists. At least one of the triangles should be visible to approaching motorists from a distance of at least 200 metres.

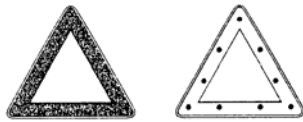

Warning Triangles should conform to
AS3790–1992 - *Portable warning triangles for motor vehicles.*

Guidelines for Coupling Semi Trailers – Practical Test Procedure

Conditions: The following conditions are to apply:

- Prime mover and trailer uncoupled and secure.
- Prime mover behind trailer.
- Firm level non-traffic area.
- Safe pedestrian access around vehicle.
- If required, use wheel chocks and suitable strong timber or flat supports.

Requirements: The driver will, during the procedure:

- Check the king pin, turn-table and its lubrication, jaws, airlines, leads and connections;
- Check jaws are open;
- Ensure trailer is secure;
- Position prime mover just forward of trailer, check entry alignment and that prime mover will clear trailer (two positioning adjustments are allowed);
- Reverse prime mover under trailer (skid plate not yet over turntable);
- Check and adjust the height of skid plate to turntable (to slightly lift trailer on connection);
- Secure the handle;
- Reverse prime mover slowly until turntable jaws lock around king pin;
- Check that coupling release lever is in locked position and there is no gap between turntable and trailer skid plate, check jaws are closed correctly;
- Connect air-hoses and cables;
- Apply trailer brake;
- Switch tractor protection valve (if fitted) to normal;
- Check brake air pressure;
- Raise the landing gear approximately 25mm.;
- Perform 'Tug Test';

- Fully raise landing gear and stow handle;
- Switch off engine and conduct a walk around inspection, listening for air leaks, stowing chocks and checking all trailer lights (assessor may assist under driver direction);
- Conduct all procedures safely and efficiently

Guidelines for Uncoupling Semi Trailers – Practical Test Procedure

Conditions: The following conditions are to apply:

- Vehicle parked and secure in a straight line.
- Firm level non-traffic area.
- Safe pedestrian access around the vehicle.
- If required, use wheel chocks and suitable strong timber or flat supports for landing gear.

Requirements: The driver will, during the procedure:

- Apply park brake and tractor/trailer protection valve;
- Ensure trailer security (by chocking wheels);
- Lower landing gear ensuring firm and even contact with the ground;
- Secure handle;
- Disconnect and secure all hoses and cables;
- Release turntable jaws;
- Raise the trailer until a gap is visible at the fifth wheel;
- Move prime mover forward slowly until the fifth wheel is just clear of the skid plate;
- Apply prime mover park brake;
- Ensure semi-trailer supports its own weight;
- Drive slowly away;
- Ensure driver's door is closed whenever vehicle is moving;
- Conduct all procedures safely and efficiently.

Definitions of Some Vehicle Types and Commonly Used Terms

Prime Mover

A motor vehicle constructed to provide the motive power for an articulated vehicle.

Hauling Unit

A prime mover or a rigid motor vehicle used to tow a trailer.

Trailer

Any vehicle without motive power constructed or adapted to be drawn by a motor vehicle.

Articulated Vehicle

A motor vehicle, the portion immediately following the prime mover of which is pivoted to, and a part of which is superimposed on the prime mover.



No longer than 19 metres

Point of articulation

Multi - Combination (more commonly known as a Road Train)

- (a) The combination of an articulated vehicle and 1 dog trailer, or a rigid vehicle and 2 dog trailers (commonly referred to as a Double Road Train) or
- (b) The combination of an articulated vehicle and 2 dog trailers, or a rigid vehicle and 3 dog trailers (commonly referred to as a Triple Road Train)

In any case, the overall length of the long combination vehicles referred to in (b) must not exceed 53.5 metres.

Fifth Wheel Assembly

Turntable of a prime mover or converter dolly trailer, and all components to fit such.

Pole-type Trailer

Means a trailer that is attached to the towing vehicle by means of a pole, or by an attachment fitted to the pole, and which is ordinarily used for transporting loads such as logs, pipes or structural members, generally capable of supporting themselves as beams between supports

Towing a Trailer

Rigid motor vehicles driven under a class "MR" licence may tow a single trailer, however the capacity of the vehicle must be suitable for the trailer to be towed. Manufacturers of trucks show the designed GCM limit appropriate for the safe operation and performance of their vehicles. This information may be detailed on the compliance plate or build plate attached to the vehicle.

The laden mass of the trailer in a vehicle combination (not being a road train) comprised of a rigid motor vehicle and a trailer shall not exceed the laden mass of the rigid motor vehicle. The towing attachment must also be suitably rated to meet towing requirements.

All trailers manufactured after 1 January 1989 with an Aggregate Trailer Mass (ATM) over 750 kg must have brakes and must comply with the standards outlined in Vehicle Standards Bulletin No. 1 published by the Federal Office of Road Safety which is available from MVR offices.

Rear Marker Plates and Marker Strips

Refer to [Motor Vehicle \(Standards\) Regulations](#) and [Traffic Regulations](#)

The following are some vehicles which **must** be fitted with rear marker plates or marker strips:

- (a) Heavy Omnibuses with a GVM exceeding 12 tonnes (except Route Service Omnibuses used solely in urban areas)
- (b) Heavy Goods Vehicles (GVM exceeding 12 tonnes), and
- (c) Heavy Trailers (Gross Trailer Mass exceeding 10 tonnes).

Plates with the words "DO NOT OVERTAKE TURNING VEHICLE" must only be fitted to:

- (a) Vehicles exceeding 7.5 metres in length;
- (b) Vehicles which are used in combination exceeding 7.5 metres in length.

Note: The fitment of marker plates and strips to vehicles less than 7.5 metres in length is optional.

When marker plates cannot be fitted to a vehicle due to size constraints, it is permissible to use marker strips. Marker strips may be used horizontally or vertically with the colour bands of all individual strips oriented to slope down and outward.

Powers of Police and Transport Inspectors

A Vehicle Compliance Transport Inspector or a Police Officer may require the driver of a vehicle to:

1. stop the vehicle and give information concerning the vehicle and load, if any, and to state name and place of abode;
2. drive or cause that vehicle to be driven not more than 30km from the current location to a weighbridge or weighing station, (or any place on the forward journey planned for that vehicle), to be weighed;
3. permit the Officer to weigh, measure and examine the vehicle and its load;
4. permit the Officer to weigh:
 5. the wheel load;
 6. the axle load;
 7. the laden mass of the vehicle;
8. produce licences and exemptions issued under legislation, and any other documentation relating to the registration or operation of the vehicle or the licensing of the driver;
9. make a vehicle legal before proceeding.

Where weigh station signs directing all heavy vehicles into the weigh station are displayed, it is mandatory for heavy vehicle drivers to comply.

Important Note:

Failure to comply with any or all of the above may result in prosecution of the driver and/or owner of the vehicle involved.

Truck Drivers and Buses

Appropriately licensed drivers may drive buses, which fit into the above categories. However the driver must have an (h) endorsement if **passengers are carried for Hire or Reward**. For further details, see MVR Information Bulletin CPV05 – How to obtain a Hire or Reward (h) Endorsement

Carriage of Dangerous Goods - refer to [Work Health Act](#)

In the NT a licence is required to carry dangerous goods and NT WorkSafe issue these licences. Full details regarding the prerequisite age and health requirements as well as details of the knowledge test requirements may be obtained by referring to your local NT WorkSafe office.

Overdimensional Vehicles and Loads

Overdimensional permits of exemption may be issued in some circumstances if a vehicle or load is over the height, width, length or mass requirements and where the load is indivisible, i.e. the load can not be broken down to smaller components.

Further information on Overdimensional Permits is available from:	Vehicle Standards – Darwin	(08) 8999 3148
	Vehicle Standards – Katherine	(08) 8973 8791
	Vehicle Standards – Alice Springs	(08) 8951 5297
	MVR Hot Line	1300 654 628

Further Information and Recommended Reading

Available from NT Motor Vehicle Registry Offices or the Internet at www.mvr.nt.gov.au

- Information Bulletin L4 – How to Obtain a Class “LR” (Light Rigid) Licence
- Information Bulletin L5 – How to Obtain a Class “MR” (Medium Rigid) Licence
- Information Bulletin L6 – How to Obtain a Class “HR” (Heavy Rigid) Licence
- Information Bulletin L7 – How to Obtain a Class “HC” (Heavy Combination) Licence
- Information Bulletin L8 – How to Obtain a Class “MC” (Multi Combination) Licence
- Information Bulletin CPV05 – How to Obtain a Hire or Reward (h) Endorsement













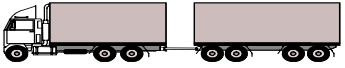

Available from NT Government Publications or the internet at:

[Motor Vehicle \(Standards\) Regulations](#)

[Traffic Regulations](#)

Contact Details	
Motor Vehicle Registry	
Telephone	1300 654 628
Facsimile	(08) 8999 3103
Email	mvr@nt.gov.au
Web	www.mvr.nt.gov.au
Postal Address	GPO Box 530 Darwin NT 0801

This list indicates what class of licence allows you to drive the vehicle shown (see Note 2).

Common Vehicle Types	Specifications	Class LR	Class MR	Class HR	Class HC	Class MC
 Rigid 2 axled vehicle	GVM greater than 4.5t but less than 8t	YES	YES	YES	YES	YES
 Rigid 2 axled Bus (See Note 1.)	Constructed or equipped to seat more than 12 adults (including driver) and GVM less than 8t	YES	YES	YES	YES	YES
 Rigid 2 axled vehicle with Pig trailer	GVM greater than 8t, and trailer to 9t - providing GCM is not exceeded, no longer than 19 metres	NO	YES	YES	YES	YES
 Rigid 3 axled vehicle	GVM greater than 8t	NO	NO	YES	YES	YES
 Rigid 3 axled vehicle with Pig trailer	GVM greater than 8t, and trailer to 9t - providing GCM is not exceeded, no longer than 19 metres	NO	NO	YES	YES	YES
 Rigid 3 axled vehicle with dog trailer	GVM greater than 8t, and trailer to 33t – providing that GCM is not exceeded, no longer than 19 metres	NO	NO	NO	YES	YES
 Rigid 4 axled (twin steer) vehicle (See Note 3.)	GVM greater than 8t	NO	NO	YES	YES	YES
 Rigid 2 axled Bus (See Note 1.)	GVM greater than 8t, and trailer to 9t – providing GCM is not exceeded	NO	YES	YES	YES	YES
 Rigid 3 axled Bus (See Note 1.)	GVM greater than 8t, and trailer to 9t – providing GCM is not exceeded	NO	NO	YES	YES	YES
 Articulated 3 Axled Bus (See Note 1)	GVM greater than 8t	NO	NO	YES	YES	YES
 Articulated vehicle with 2 axled trailer	GVM greater than 8t, and trailer to 9t – providing GCM is not exceeded, no longer than 19 metres	NO	NO	NO	YES	YES
 Articulated vehicle with 3 axled trailer	GVM greater than 8t, and trailer to 20t – providing GCM is not exceeded, no longer than 19 metres	NO	NO	NO	YES	YES
 Multi Combination (“B Double”) Cannot exceed 25 metres		NO	NO	NO	NO	YES
 Multi Combination (Articulated Vehicle with 1 dog trailer)		NO	NO	NO	NO	YES
 Multi Combination (Articulated vehicle with 2 dog trailers) Cannot exceed 53.5 metres		NO	NO	NO	NO	YES

NOTE 1: A licence “h” endorsement is required to operate for Hire and Reward.

NOTE 2: A “B” condition on your class “LR” or above licence indicates that the licence is restricted to heavy vehicles (> 4.5Ton) that only have a synchromesh transmission.

NOTE 3: A higher licence class may be required if towing a trailer.