

SECTION 3

SAMPLING AND TESTING

AGGREGATE

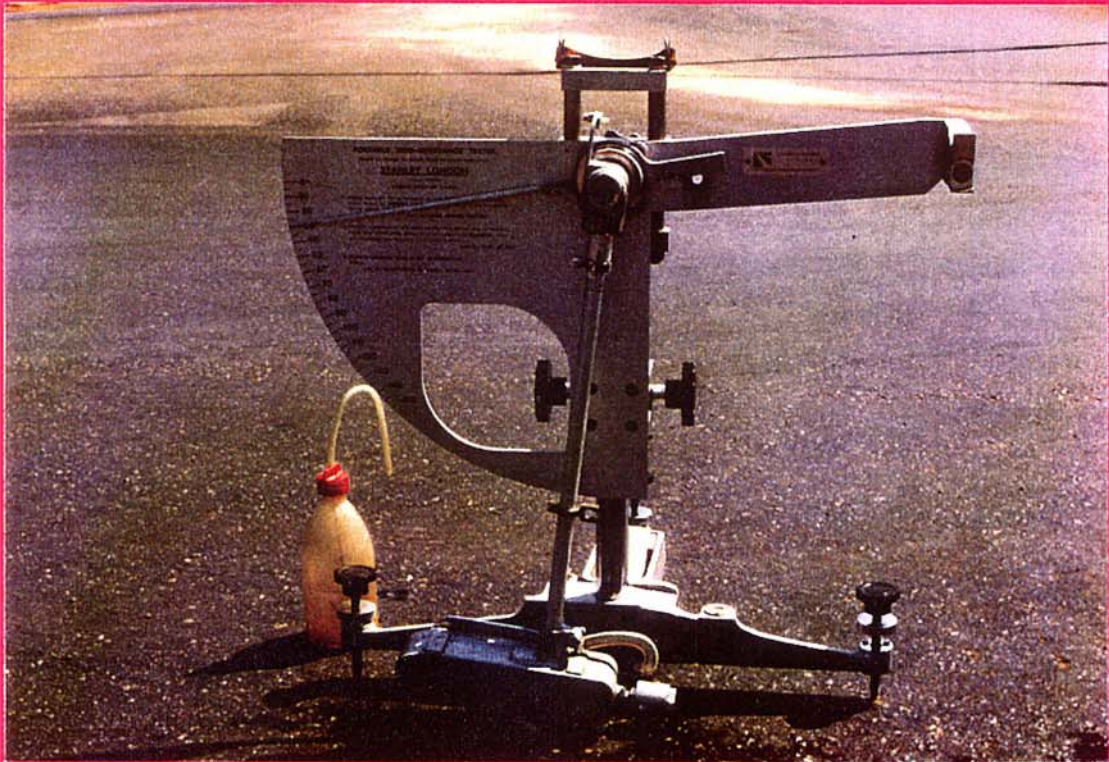



Road Projects Division

INDEX OF TEST METHODS

TEST METHOD	REVISED DATE	SECTION 3 - SAMPLING & TESTING AGGREGATES
NTTM 302.2	06 / 03	Wet/Dry Cycle - Durability Test. (Minus 100mm size)
NTTM 302.3	06 / 03	Wet/Dry Cycle - Durability Test. (Plus 100mm size)
NTTM 304.1	06 / 03	Skid Resistance Using the Portable Pendulum Tester.
NTTM 305.1	06 / 03	Pavement Surface Texture Depth.



WET DRY CYCLE (DURABILITY) TEST (MINUS 100mm SIZE)

1. SCOPE

This method describes the standard laboratory procedure for determining the resistance of rock spalls or aggregate to repeated soaking and drying cycles. It provides information to assist in assessing the soundness of rock spalls or aggregates when used as protection rock, armour rock or riprap subject to exposure and weathering action.

This test method has been adapted from the Queensland Water Resources Commission method.

2. APPARATUS

- (i) Oven - complying with the requirements of AS 1289.0. Thermostatically controlled to operate at the following temperatures:
 - low temperature 55°C to 60°C
 - high temperature 105°C to 110°C
- (ii) Sieves - as required, complying with AS 1152
- (iii) Balance - of adequate capacity, and accuracy of 5g
- (iv) Metal trays - of suitable capacity to allow the sample to be immersed in testing fluid and covered by a depth of at least 15mm as per Procedure 5(e).
- (v) Sledgehammer - (of suitable weight) or crusher.

3. SAMPLING

By AS 1141.3.2 (Sampling of Rock Spalls, Boulders and Drill Core).

4. PREPARATION

The sample shall be broken down by sledgehammer to produce approximately 20kg of well graded aggregate passing the 100mm sieve, retained 9.5mm sieve (see Notes 1 and 2).

5. PROCEDURE

- (a) Thoroughly wash (with potable water) approximately 20kg of the sample over a 9.5mm sieve. Discard all material passing the 9.5mm sieve. Dry the sample to constant mass at a temperature between 105°C to 110°C.
- (b) Sieve the sample over a 9.5mm sieve, either by hand or mechanical shaker. Discard all material passing the 9.5mm sieve (see Note 3).
- (c) Count and record the number of rock pieces retained on the 9.5mm sieve.
- (d) Weigh and record the dry mass retained on the 9.5mm sieve, (m1) to an accuracy of 5g.
- (e) Place the sample in a metal tray/s and immerse the sample in the testing fluid for 16 to 72 hours (see Note 4). The sample shall be covered by a depth of at least 15mm and kept at room temperature.
- (f) At the end of the immersion period, drain the sample. Place the sample in the low temperature drying oven for 16 to 72 hours.
- (g) Remove the sample from the oven, allow it to cool to room temperature and immerse again in the testing fluid. Repeat the process of alternate immersion and drying until five cycles have been completed.
- (h) Inspect the sample. If significant breakdown has occurred then dry to constant mass at a temperature between 105°C to 110°C (see Note 5). Sieve the sample using a 9.5mm sieve. Weigh and record the mass retained on the 9.5mm sieve (m2). Discard all material passing the 9.5mm sieve.



Road Projects Division

TEST METHOD : NTTM 302.2

REVISED DATE : 06/03

SHEET : 2 OF 3

- (i) Repeat the process of alternate immersion and drying for a further fifteen cycles (i.e. a total of 20 cycles). After each five cycles, inspect the sample for breakdown. If significant breakdown has occurred after any set of five cycles, repeat step (h) (see Note 5).
- (j) At the completion of the test, dry the sample to constant mass at a temperature between 105°C to 110° C, then sieve the sample using a 9.5mm sieve. Weigh and record the mass retained on the 9.5mm sieve (m2). Count and record the number of rock pieces retained on the 9.5mm sieve. Discard all material passing the 9.5mm sieve.

6. CALCULATION

The Wet/Dry Durability (WDD) is assessed as the amount of material retained on the 9.5mm sieve expressed as a percentage of the original dry mass at the start of the test.

$$WDD = \frac{m2 \times 100}{m1}$$

This calculation is performed for each time the sample mass was determined.

7. REPORT

The percent passing (WDD) shall be reported to the nearest 0.1 percent and shall be reported with the number of cycles. Report the WDD for each recorded set of cycles (Procedure 5 (g), (h), (i) & (j)).

8. PRECISION

Results obtained by one operator using the same equipment in repeat tests on different samples drawn from a single bulk sample should not vary by more than ten percent.

NOTES ON METHOD:

- 1. Care shall be taken when breaking down rock spalls with the sledgehammer not to unduly fracture the material.
- 2. A well graded aggregate has a continuous distribution of grain sizes from the 100mm size to the 9.5mm size.
- 3. Sieving may be done by hand or with a mechanical shaker. When sieving by hand, continue sieving until the mass passing the sieve in 1 minute is less than 1 percent of the mass of material retained on the sieve. In the case of mechanical sieving, determine the minimum sieving time by comparison with hand sieving. Do not overload sieves.
- 4. The testing fluid is usually tap water at room temperature, but may be natural ground water, seawater, a dilute acid with a dispersing agent as appropriate to the anticipated environment of the rock.
- 5. Significant breakdown is defined (for the purpose of this test) as any flaking, splitting, disintegration or other breakdown of the rock mass or rock substance, that can be visually ascertained and which results in a percent passing the 9.5mm sieve of 2% or more.
- 6. The test is terminated after a total of twenty cycles, but may be terminated earlier if breakdown is severe, or may be extended beyond twenty cycles if necessary. Severe breakdown is defined (for the purpose of this test) as any flaking, splitting, disintegration or other breakdown of the rock mass or rock substance, that is readily apparent visually and which results in a percentage passing the 9.5mm sieve of 5% or more.
- 7. Photography of the sample at various stages throughout the test can assist with qualitative assessment and reporting.
- 8. Information gained from this test shall be used as a guide for determining the acceptability of aggregate for use as protection rock and/or riprap.



Northern Territory Government

Department of Infrastructure, Planning and Environment

TEST METHOD : NTTM 302.2

REVISED DATE : 06/03

SHEET : 3 OF 3

WET DRY CYCLE (DURABILITY) TEST

PROJECT:

SAMPLE NO:

FEATURE:

MATERIAL TYPE:

Initial Oven Dry Mass (M1) = g

$$WDD = \frac{M2 \times 100}{M1}$$

Progressive Oven Dry Mass (M2)

Cycle No.	Immersion Date		Low Temp Oven Date		No. of Rock Pieces	
	In	Out	In	Out	Commencement	Completion
1						m2 =
2						
3						
4						WDD @5 CYC. = _____%
5						
6						m2 =
7						
8						
9						WDD @ 10 CYL. = _____%
10						
11						m2 =
12						
13						
14						WDD @ 15 CYL. = _____%
15						
16						m2
17						
18						
19						WDD @ 20 CYL = _____%
20						
21						m2 =
22						
23						
24						WDD @ 25 CYL = _____%
25						
26						m2 =
27						
28						
29						WDD @ 30 CYL = _____%
30						



Road Projects Division

TEST METHOD : NTTM 302.3

REVISED DATE : 06/03

SHEET : 1 OF 3

WET DRY CYCLE (DURABILITY) TEST (PLUS 100mm SIZE)

1. SCOPE

This method describes the standard laboratory procedure for determining the resistance of rock spalls of size 100-300mm, to repeated soaking and drying cycles. It provides information to assist in assessing the soundness of rock spalls when used as protection rock, armour rock or riprap subject to exposure and weathering action.

This test method has been adapted from the Queensland Water Resources Commission method.

2. APPARATUS

- (i) Oven - complying with the requirements of AS 1289.0. Thermostatically controlled to operate at the following temperatures:
 - low temperature 55° C to 60° C
 - high temperature 105° C to 110° C
- (ii) Sieves - as required, complying with AS 1152
- (iii) Balance - of adequate capacity, and accuracy of 5g
- (iv) Metal trays or water bath of suitable capacity to allow the rock spalls to be immersed in the testing fluid and covered by a depth of at least 30mm, as per Procedure 5(b).
- (v) Sledgehammer - of suitable weight.

3. SAMPLING

By AS 1141.3.2 (Sampling of Rock Spalls, Boulders and Drill Core). In particular note the following: "Sampling shall be carried out with the utmost of care and integrity by properly trained personnel, otherwise test results obtained from the samples may misrepresent the characteristics of the material." All sampling shall be done by the testing laboratory. "Sampling shall be conducted by means which ensure that the samples represent, as far as practicable, the true nature of the main body of material from which they were drawn."

Visually assess the rock spalls in the stockpile to be sampled and evaluate the strength and other characteristics of the rock spalls with a hammer or other means. From this evaluation, select 5 to 8 representative spalls of the rock in the size range 100mm to 300mm (weight 25 to 40kg) that can be handled without undue difficulty. If necessary these may need to be obtained by breaking larger stones with a sledgehammer (see Note 1).

4. PREPARATION

- (a) Thoroughly wash the sample and scrub with a wire brush until clean, using potable water. Dry the sample to constant mass at a temperature between 105°C to 110°C.
- (b) Number each rock spall with paint or other indelible mark.
- (c) Photograph each rock spall sufficiently to enable any subsequent breakdown to be visually discerned (see Note 5).



Road Projects Division

TEST METHOD : NTTM 302.3

REVISED DATE : 06/03

SHEET : 2 OF 3

5. PROCEDURE

- (a) Weigh and record the dry mass of each rock spall to an accuracy of 5g. The combined mass of all rock spalls shall be recorded. Label each rock spall and photograph.
- (b) Place the rock spalls in a metal tray/s or water bath and immerse the spalls with the testing fluid for 16 to 48 hours (see Note 2). The spalls shall be covered by a depth of at least 30mm and kept at room temperature.
- (c) At the end of the immersion period, drain the rock spalls for at least 10 minutes and/or towel dry the excess fluid until the rock spalls attain the saturated surface dry condition. Place the rock spalls in the low temperature drying oven for 8 to 48 hours.
- (d) Remove the rock spalls from the oven and immediately immerse them again in the testing fluid.
- (e) Repeat the process of alternate immersion and drying until five cycles have been completed.
- (f) Inspect the sample. If nil or insignificant breakdown has occurred, then proceed to step (g). If significant breakdown has occurred, (see Note 3) then dry to constant mass at a temperature between 105° C to 110° C. Sieve each rock spall on the 75mm sieve. Weigh and record the mass of each rock spall. Record the combined mass of all rock spalls retained on the 75mm sieve. Retain for future inspection all material passing the 75mm sieve. Photograph if appropriate (see Note 5).
- (g) Repeat the process of alternate immersion and drying for a further fifteen cycles (i.e. a total of 20 cycles). After each five cycles, inspect the sample for breakdown. If significant breakdown has occurred after any set of five cycles, repeat step (f).
- (h) At the completion of the test (see Note 4), dry the sample to constant mass at a temperature between 105° C to 110° C, then sieve the sample using a 75mm sieve. Weigh and record the mass of each rock spall. Record the combined mass of all rock spalls retained on the 75mm sieve. Retain for inspection all material passing the 75mm sieve. Photograph the rock spalls and the material passing the 75mm sieve. Describe the condition of each rock spall in terms of flaking, splitting, disintegration or other breakdown of the rock mass and rock substance.

6. CALCULATION

Calculate the percentage loss of material for each rock spall and the total sample each time significant breakdown occurred and the sample mass was determined (steps (e) and (g)).

7. REPORT

Provide a qualitative and quantitative assessment of the durability of the rock in relation to the proposed use of the rock. Describe the condition of each rock spall in terms of flaking, splitting, disintegration or other breakdown of the rock mass and rock substance. Report the percentage loss for each rock spall and the total sample each time significant breakdown occurred and the sample mass was determined. The percent passing shall be reported to the nearest 0.1 percent and shall be reported with the number of cycles. The dates of the start and completion of the test shall be reported. Initial and final masses of all rock spalls shall be reported. All photographs shall be supplied. Report all test conditions.



Road Projects Division

TEST METHOD : NTTM 302.3

REVISED DATE : 06/03

SHEET : 3 OF 3

NOTES ON METHOD:

1. Care shall be taken when breaking down rock spalls with the sledgehammer not to unduly fracture the material.
2. The testing fluid is usually tap water at room temperature, but may be natural ground water, seawater, a dilute acid or a dispersing agent as appropriate to the anticipated environment of the rock.
3. Significant breakdown is defined (for the purpose of this test) as any flaking, splitting, disintegration or other breakdown of the rock mass or rock substance, that can be visually ascertained and which results in a percent passing the 75 mm sieve of 2% or more after 5 cycles.
4. The test is terminated after a total of twenty cycles, but may be terminated earlier if breakdown is severe, or may be extended beyond twenty cycles if considered necessary, for example if breakdown is only just starting to appear. Severe breakdown is defined (for the purpose of this test) as any flaking, splitting, disintegration or other breakdown of the rock mass or rock substance, that is readily apparent visually and which results in a percentage passing the 75mm sieve of 5% or more after 5 cycles.
5. Photography of the sample at various stages throughout the test is aimed at assisting the qualitative assessment and reporting.
6. Information gained from this test shall be used as a guide for determining the acceptability of rock spalls for use as protection rock, armour rock or riprap.



DETERMINATION OF SKID RESISTANCE WITH THE PORTABLE SKID TESTER

1. SCOPE

This method describes the procedure for determining the skid resistance value of a surface. The test is performed on sealed driving surfaces, under wet conditions.

2. DEFINITION

The skid resistance value of a surface is a measure of the frictional resistance between a rubber slider and the test surfaces.

3. APPARATUS

(a) Pendulum Friction Tester

A tester and auxiliary scale constructed in accordance with details available from the Australian Road Research Board, Melbourne (see Figure 1). All bearings and working parts of the instrument shall be enclosed as far as possible, and all materials used shall be suitably treated to prevent corrosion under wet conditions.

The tester shall be used and stored in a dust free environment and one which is not subject to a large temperature variation.

The pendulum friction tester shall be calibrated to ensure compliance with the following requirements at intervals not exceeding 2 years or when results obtained from the friction tester control specimens vary from the established values by more than 3 units (see Note 1).

The tester shall incorporate the following:

- (i) A spring loaded rubber slider of the properties specified in Clause 3 (b) mounted on the end of a pendulum arm so that the sliding edge is 515 ± 2 mm from the axis of suspension.
- (ii) Means for levelling the instrument.
- (iii) Means for raising and lowering the axis of suspension of the pendulum so that the slider can:
 - swing clear of the surface of the specimen; and
 - be set to slide over a fixed length of surface
- (iv) Means for holding and releasing the pendulum arm so that it falls freely from a horizontal position.
- (v) A pointer balanced about the axis of suspension, indicating the position of the pendulum arm throughout its forward swing and moving over the circular scale attached to the instrument. The mass of the pointer, excluding felt friction washers, shall be not more than 85g and the friction in the pointer mechanism shall be adjustable so that, with the pendulum arm swinging freely from a horizontal position, the outward tip of the pointer may be brought to rest on the forward swing of the arm at a point 10mm below the horizontal, the point corresponding to the zero position on the attached circular scale.

The mass of the swinging arm including the slider shall be 1.5 ± 0.03 kg with the centre of gravity lying on the axis of the arm at a distance of 410 ± 5 mm from the centre of suspension.



Road Projects Division

TEST METHOD : NTTM 304.1

REVISED DATE : 06/03

SHEET : 2 OF 8

The slider shall be mounted on an axis set at an angle of 25° ± 1° to the horizontal when the pendulum is at the lowest point of its swing, so that only the rear edge of the slider contacts the test surface. The slider can turn about its axis without obstruction to follow unevenness of the surface.

The slider shall be spring loaded against the test surface and the nominal static force on the slider is set by the calibration procedure (see Note 1).

NOTE 1: Calibration of the friction tester is available through the Australian Road Research Board, Melbourne. Alternatively, calibration may be arranged through local laboratories having NATA certification for calibration of friction testers.

(b) Rubber Sliders

Rubber sliders used in the friction tester shall be 24 ± 1mm deep and 6 ± 1mm thick and rigidly backed. The sliding edges shall be square, clean cut and free from contamination. Avoid handling the surfaces of sliders at all times.

The rubber used in the sliders shall comply with the requirements given in Table 1.

When not in use, sliders shall be stored in the dark at a temperature between 10°C and 25°C. They shall be discarded when:

- they are more than 12 months old from the date stamped on the slider; or
- they do not comply with the requirements of Table 1; or
- the two available edges of the slider have each become rounded.

TABLE 1
PROPERTIES OF SLIDER RUBBER

Table with 6 columns: Property, Temperature (0, 10, 20, 30, 40), and rows for Resilience, Hardness, and IRHD.

* Lupke rebound test in accordance with BS 903: Part A8

† International rubber hardness degrees in accordance with BS 903: Part A26

NOTE 2: Rubber sliders complying with this standard are available through the Australian Road Research Board, Melbourne

(c) Water Spray Bottle

Water spray bottle containing clean potable water at ambient temperature.

(d) Thermometer

The thermometer shall have a range of 0°C to 50°C in accordance with AS 1141.2.

(e) Supply of distilled or potable water.



Road Projects Division

TEST METHOD : NTTM 304.1

REVISED DATE : 06/03

SHEET : 3 OF 8

4. PREPARATION OF TEST SURFACE

- (a) Inspect the road and visually choose representative section(s) to be tested
- (b) Ensure that the test surface is free from loose grit and other debris by washing clean with water.

5. SETTING THE TESTER

- a) Set the base level by means of the spirit level and three levelling screws on the base frame (Note 4).
- b) Raise the head so that the pendulum arm swings clear of the surface (Note 3).

NOTE 3: Movement of the head of the tester (carrying the swinging arm, graduated scale, pointer and release mechanism) is controlled by a rack and pinion on the rear of the vertical column. After unclamping the locking knob A at the rear of the column, the head may be raised or lowered by turning either of the two knobs B. When the required height is obtained, the head unit must be locked in position again by clamping knob A.

NOTE 4: Ensure that the feet on the levelling screws are adjusted correctly, to prevent the levelling screws from indenting the bitumen seal in hot conditions.

6. CALIBRATION OF EQUIPMENT

- (a) Checking the zero setting as described in Note 5.

NOTE 5: This is done by first raising the swinging arm to the horizontal release position, on the right hand side of the apparatus. In this position it is automatically locked in the release catch. The pointer is then brought round to its stop, in line with the pendulum arm.

The pendulum arm is released by pressing button C. The pointer is carried with the pendulum arm on the forward swing only. Catch the pendulum arm on its return swing, and note the pointer reading. Return the arm to the release position.

- (b) Correct the zero setting as necessary by adjustment of the friction rings E. (see Note 6).

NOTE 6: If the pointer has swung past the zero position rings E are screwed up a little more tightly. If it has not reached zero the rings should be unscrewed a little.

This adjustment is necessary as the tester may be used under different temperature conditions and in windy conditions: sufficient adjustment has been allowed to cover all normal ranges of temperatures encountered, but some difficulty may be experienced in correcting the zero in very high winds - it may be necessary to operate the tester with a wind shield.

7. PROCEDURE

- (a) With the pendulum arm free, and hanging vertically, place the sliding spacer under the lifting handle setting-screw to raise the slider.
- (b) Lower the head of the tester using knobs A & B so that the slider just touches the road surface, and clamp in position with knob A.
- (c) Remove the spacer.



Road Projects Division

TEST METHOD : NTTM 304.1

REVISED DATE : 06/03

SHEET : 4 OF 8

- (d) Check the sliding length of the rubber slider over the surface under test, by gently lowering the pendulum arm until the slider just touches the surface on one side and then on the other side of the vertical.

NOTE 7: The sliding length is the distance between the two points where the sliding edge of the rubber touches the test surface.

To prevent undue wear of the slider when moving the pendulum arm through the arc of contact, the slider should be raised off the road surface by means of the lifting handle.

- (e) If necessary, adjust to the correct length by raising or lowering the head slightly.

NOTE 8: When the apparatus is set correctly the sliding length should be between 12.4 and 12.7cm on the scale provided, (the outer marks are 12.7 cm apart and the inner ones are 12.4cm apart).

- (f) Place the pendulum arm in its release position.

- (g) The apparatus is now set for the test operation

8. OPERATION OF THE TESTER

- (a) Wet the road surface and slider ensuring that the road surface is free from loose grit or other debris.
- (b) Bring the pointer round to its stop.
- (c) Release the pendulum arm by pressing button 'C' and catch it on the return swing before the slider strikes the road surface.
- (d) Note the reading indicated by the pointer.

NOTE 9: If the slider is not wetted as well as the road surface the reading obtained on this first swing should be discarded.

- (e) Return the arm and pointer to the release position, keeping the slider clear of the road surface in this operation by means of the lifting handle.

- (f) Operate the pendulum and pointer for five swings, rewetting the test surface and slider before each swing. Read and record the value from each swing.

- (g) Record the mean of five successive readings, provided they do not differ by more than 3 units.

- (h) If the range is greater than this, repeat swings until three successive readings do not differ by more than 3 units.

- (i) Successive swings of the pendulum should always show the same or a lower friction value. If the second, third, fourth or fifth swing shows a higher value than any of the preceding values, a fault is indicated and must be rectified before proceeding. Usually the fault is an increased contact length between slider and surface, check the contact length and reset if necessary.

- (j) Average the values obtained in 8(f), 8(g), or 8(h) and record the average as the skid resistance value uncorrected for temperature (SRVt).



Road Projects Division

TEST METHOD : NTTM 304.1

REVISED DATE : 06/03

SHEET : 5 OF 8

9. PROCEDURE WHEN TESTING ROAD SURFACES

- (a) Inspect the road and visually choose a representative section to be tested.
- (b) Set the apparatus on the road surface in the track chosen to be tested, so that the slider swings in the direction of the traffic.
- (c) Take the mean of five readings, as above, at each location in the test track spaced at approximately 10 metres along the length under test.
- (d) The mean of these readings gives a representative value of skidding resistance of the section of the road.

NOTE 10: If the leading edge of the rubber slider becomes worn or rounded, rotate the rubber slider and use the other side. Once both edges of the rubber slider are worn or rounded, discard the rubber slider.

10. RECORDING OF DATA

Record the temperature ($t^{\circ}\text{C}$) of the water lying on the road immediately after the test (Note 11).

NOTE 11: Investigations have shown that rubber resilience is temperature dependent and changes in rubber resilience will effect the skid resistance measurements: skid resistance tends to fall as temperature rises.

The correction equation to obtain SRV_{40} based on surface temperature measurement is:

$$\text{SRV}_{40} = \frac{\text{SRV } t}{1 - 0.00525 (t-40)}$$

NOTE 12: The correction procedure in most common use and shown in Road Research Laboratory Road Note 27, 1969 is not suitable for Australian conditions.

11. MAINTENANCE OF EQUIPMENT

- (a) At the completion of testing remove the rubber slider and wrap in tissue paper and place in a plastic bag. Store in a cool dark environment at 10 to 25 degrees C.
- (b) If the rubber slider has not been used for more than 4 weeks, the slider shall be given a few swings on a dry surface to clean and liven up the surface of the rubber prior to any testing.



Road Projects Division

TEST METHOD : NTTM 304.1

REVISED DATE : 06/03

SHEET : 6 OF 8

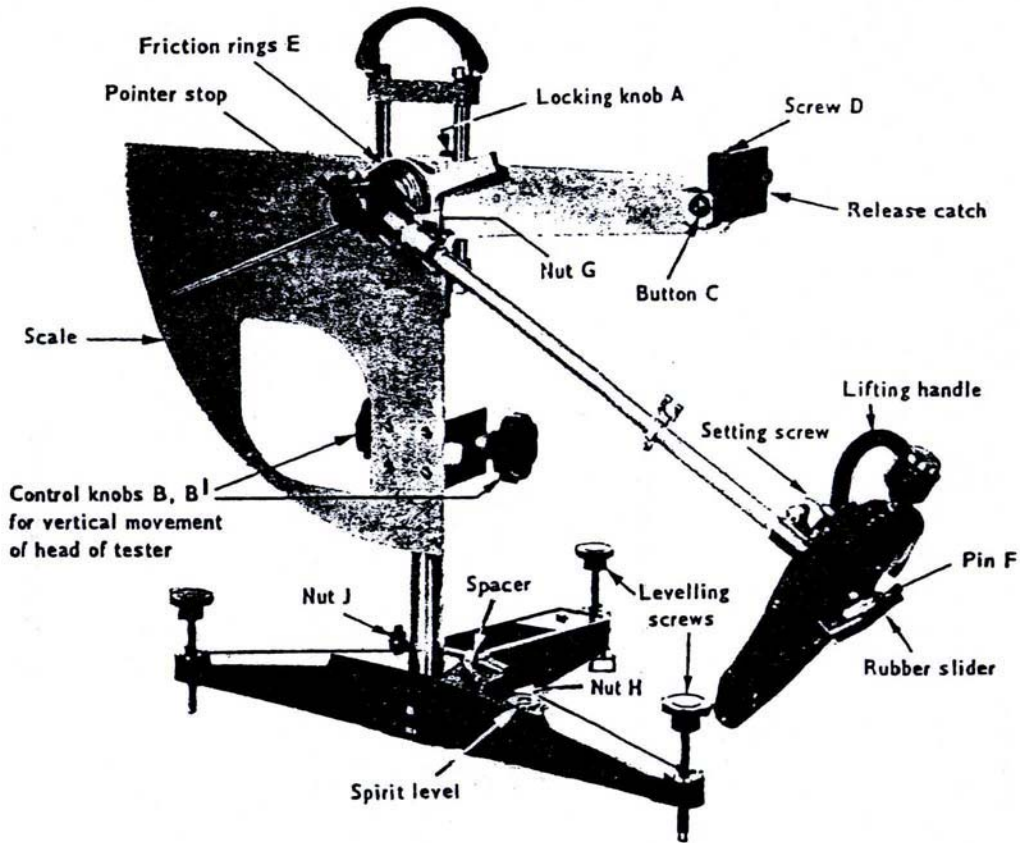
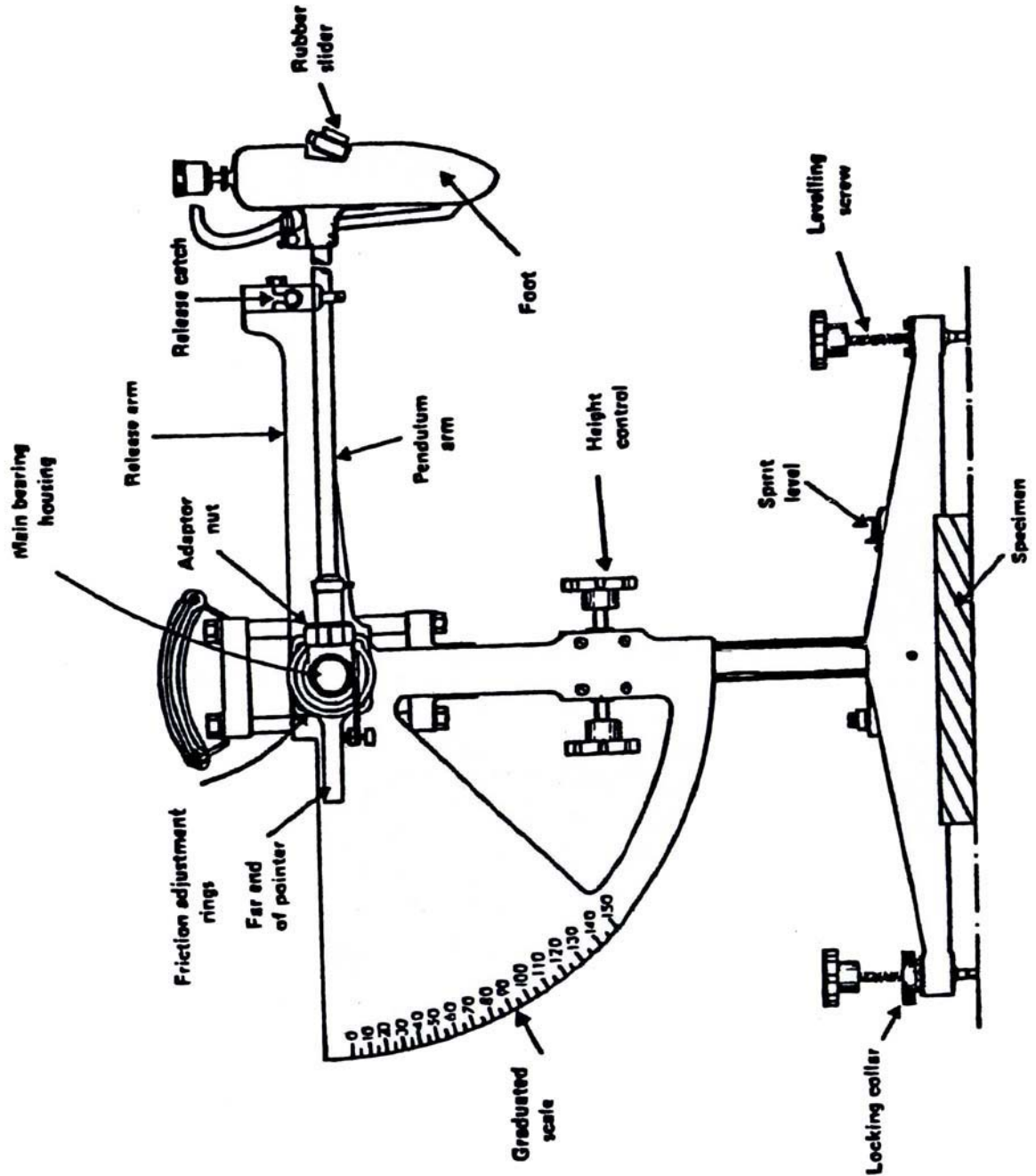



FIGURE 2 - PORTABLE SKID RESISTANCE TESTER





Road Projects Division

TEST METHOD : NTTM 304.1

REVISED DATE : 06/03

SHEET : 8 OF 8

TABLE 2

Suggested values of skid resistance for use with the portable tester.

Category	Type	Skid Resistance on Wet Surface	Standard of Skidding Resistance Represented
A	<i>Difficult sites</i> , such as roundabouts; bends with radius less than 500 ft on derestricted roads; gradients, 1 in 20 or steeper and of length greater than 100 yd; approaches to traffic lights on derestricted roads.	Above 65	'Good': fulfilling the requirements even of fast traffic and making it most unlikely that the road will be the scene of repeated skidding accidents.
B*	General requirements, i.e. roads and conditions not covered by categories A and C.	Above 55	Generally satisfactory: meeting all but the most difficult conditions encountered on the roads.
C*	Easy sites, for example, straight roads, with easy gradients and curves, and without junctions, and free from any features such as mixed traffic, especially liable to create conditions of emergency.	Above 45	'Satisfactory only in favourable circumstances'
D	All sites.	Below 45	'Potentially slippery'

* On smooth looking or fine-textured roads in these categories vehicles having smooth tyres may not find the 'skid-resistance' adequate. For such roads accident studies should also be made, i.e. ensure that there are no indications of difficulties arising from skidding under wet conditions.



DETERMINATION OF PAVEMENT SURFACE TEXTURE DEPTH SAND PATCH METHOD

1. SCOPE OF METHOD

This test method details the Sand Patch method of test for determining the surface texture depths of Portland cement concrete, bituminous concrete, and bituminous sealed pavements.

2. LIMITATIONS

The Sand Patch test should not be undertaken under adverse conditions such as exist when pavements are wet, or the strength of the wind is sufficient to disturb the sand particles used during the test. The use of a suitable wind screen may provide sufficient shelter to allow the test to be carried out under windy conditions.

3. APPARATUS

- (a) A metal cylinder of 100 mm internal depth and 20 mm internal diameter.
- (b) A flat wooden disc 65mm diameter with a hard rubber disc 2 mm thick attached to one face, the reverse face being provided with a handle.
- (c) Dry natural sand or glass beads with rounded particle shape and which will pass a 0.3mm sieve and be retained on a 0.15mm sieve.

4. PROCEDURE

- (a) Dry the surface to be measured and sweep clean with a soft brush.
- (b) Fill the cylinder with sand, tapping the base three (3) times on the surface to ensure compaction, and strike off the sand level with the top of the cylinder.
- (c) Carefully pour the sand into a conical heap on the surface to be tested.
- (d) Holding the handle of the wooden disc between the thumb and fore finger, and without applying vertical pressure on the disc, spread the sand in a spiral motion from the centre of the heap so that the sand is spread into a circular patch. Care must be taken to maintain the face of the disc horizontal at all times.
- (e) Continue to spread the sand using a spiral motion to maintain a circular patch until the surface depressions are filled with sand to the level of the surface peaks.
- (f) Measure the diameter of the circular patch to the nearest 5mm at four (4) equally spaced locations, and average the results.

5. CALCULATION

Calculate the surface texture depth of the pavement using the formula

$$\text{Surface Texture Depth} = \frac{40,000}{d^2} \text{ mm}$$

where d is the average diameter of the patch in millimeters.

6. REPORT

Report the surface texture depth to the nearest one-hundredth of a millimeter.