

## Proposed Changes to Planning Rules and Guidelines for Darwin's Future

The Northern Territory Government will release for public comment proposed changes to the NT Planning Scheme to improve building development in Darwin's CBD to better reflect our tropical city.

Consultation with the development industry, building owners and stakeholders has contributed to the amendments.

The changes combine recent consultations with stakeholders focused on building heights and volumetric controls in the CBD and outcomes of the Northern Territory Government's Darwin CBD Urban Planning Forum.

The forum, an initiative of the Capital City Committee, focused on building height, tropical building design, building sustainability, links and views of the harbour from the city centre, entry to the city, buildings interacting at ground level, including covered walkways, landscaping, the amenity of the CBD's public domain and performance outcomes in the NT Planning Scheme.

The key focus of the proposed changes include providing more certainty on building heights, improving building interaction and street frontage and providing for peer review on the design of major developments.

### The proposed changes

- Building height in the Darwin CBD to be limited to 90 metres above ground level
- Introduction of volumetric control on new buildings with a two-tier scheme: a podium (tier 1) and a tower (tier 2)
- Requirement for active street frontage on 75% of the development site
- Incorporating the Guiding Principles on building design for Darwin's CBD into the planning scheme
- Introduction of UDAP peer review on any development application for sites greater than 2000sq m
- On-site parking to be screened from street
- Provision of awnings over priority pedestrian corridors

## The proposed changes in detail

### Building height in the Darwin CBD to be limited to 90 metres above ground level

These changes will replace an Interim Development Control Order which prescribed building height limits in various areas of the CBD to provide more certainty, similar to what existed in the Planning Scheme as a guide only, until broader consultation on height and volumetric control could occur.

The building height change is complemented by new volumetric controls on new buildings to improve design, interaction and street frontage.

### Introduction of volumetric control on new buildings with a two-tier scheme: a podium (tier 1) and a tower (tier 2)

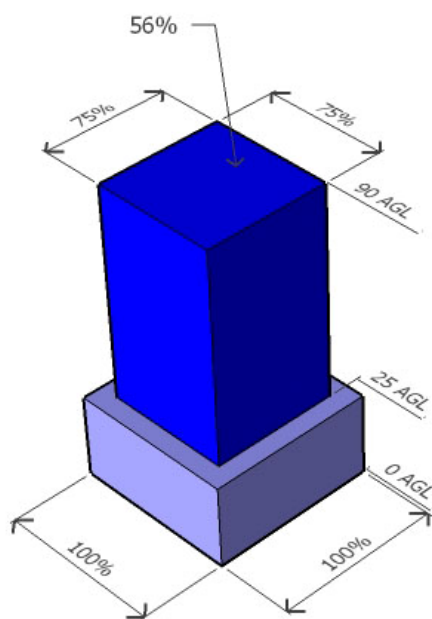

A new volumetric control scheme will apply to all new building developments.

The scheme proposes two-tiers:

Tier 1 – can apply to 100% of the site with a maximum effective height of 25 metres.

Tier 2 - is set back by a minimum of 6 metres off all boundaries with a maximum height of 90 metres to the top of the highest structure.

Other principles within this scheme include:

- 75% of the street frontage is to be active
- minimum setback of 6 metres to all windows, doors and balconies to all habitable rooms at Tier 1.

### Incorporating Guiding Principles into the Planning Scheme

Guiding Principles will be established and incorporated into the Planning Scheme to provide developers more guidance on building design to improve building interaction for our tropical city.

These principles will articulate building shade and awnings, landscaping and other elements to improve the look and feel of Darwin city.

### **Introduction of UDAP peer review on any development application for sites greater than 2000sq m**

The peer review will consider the proposed built form of any development on a site 2000sq m or greater.

The peer review will consider the design aspects of the building and provide advice to the developer and the Development Consent Authority.

It is proposed the review will occur at the development applications stage, early in the design process.

### **On-site parking to be screened from street**

Improving car park facades was an outcome of the Darwin CBD Urban Planning Forum.

It is proposed to amend the Planning Scheme to require all on-site parking to be screened from the street for new developments.

### **Provision of awnings over priority pedestrian corridors**

Providing more shade and protection from tropical weather through covered pedestrian corridors was an outcome of the Darwin CBD Urban Planning Forum.

It is proposed to amend the Planning Scheme to require all new developments to provide awnings over priority pedestrian corridors.