

DARWIN PORT CORPORATION

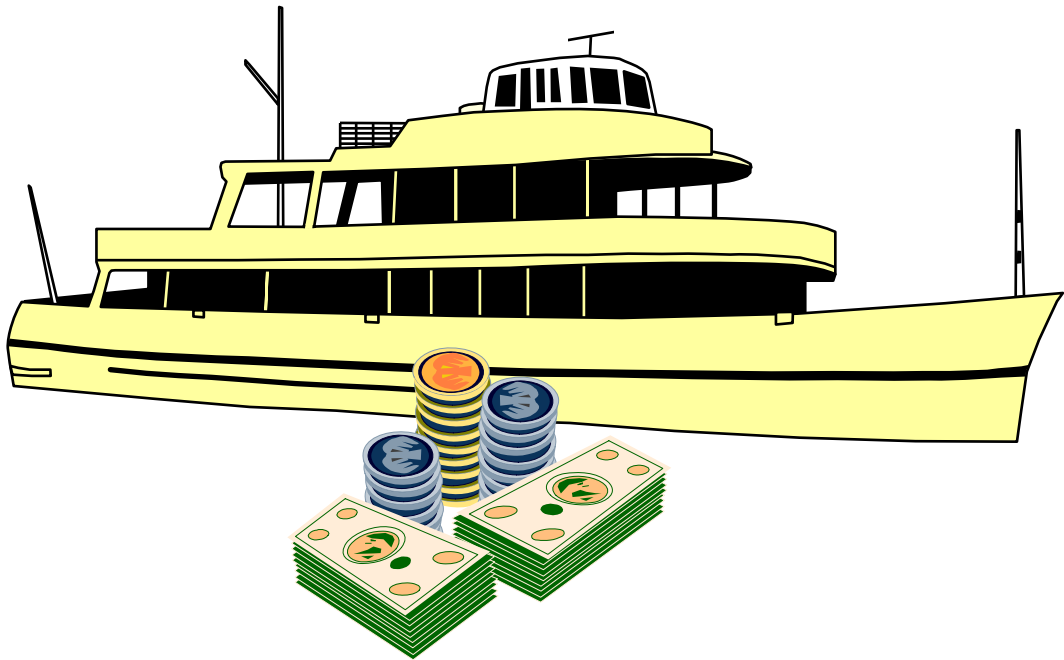

MOORING BASIN CHARGES



Version 1

July 2003

DARWIN PORT CORPORATION	Issue Status	Issue 2
	Issue Date	1 July, 2003
	Authorisation	W. Bruce Wilson
	Page No.	2

Amendment History

Version	Date	Reason for Change	Document/ Para Ref	Made By	Description of Change
1.0	Aug 2000	Original			approved by Bruce Wilson (Harbourmaster)
1.0	July 2003	3% increase in main Port Chgs		Mark Dyer	approved by Bruce Wilson (Harbourmaster)
1.0	Feb 2009	Change tariff wording	Page 7	Leah Atkinson	Approved Business Manager



Conditions of credit are explained in the Darwin Port Corporation Credit / Debt Management Plan Oct 2002 a copy of which is located on our website (www.darwinport.nt.gov.au)

Prices are GST inclusive.

DPC Charges Amended 01 July, 2003

D:\Documents and Settings\tc6\Local Settings\Temporary Internet Files\OLKCB\DPC - Mooring Basin Charges Feb 2009.doc

DARWIN PORT CORPORATION	Issue Status	Issue 2
	Issue Date	1 July, 2003
	Authorisation	W. Bruce Wilson
	Page No.	3

See also DPC Main Port Charges

TABLE OF CONTENTS

A

Additional Vessels in Berths	16
---	----

B

Basin Operating Policy	5
Basin Overview	5

C

Caretaker Tenancy	16
Company hire of Berths & Nominated Vessels	16
Customer Trading Terms	8

D

Daily Rental Pleasure Craft	9
Daily Surcharge Rates	9
DPC Contact Details	19
DPC Web Address	5

E

Equipment Hire	17
-----------------------------	----

F

Facilities	17
Fishing and Commercial Vessels	8
Fouling Of The Basin	6

G

General Information	16
---------------------------	----

I

Information Hirers Must Provide	8
---------------------------------------	---

L

Lock Hours	7
Lock Operating Procedures	7
Lock Operations	7

M

Mooring Patterns	11
Cyclonic Conditions - Two Empty Berths	14
Mooring Patterns	



Conditions of credit are explained in the Darwin Port Corporation Credit / Debt Management Plan Oct 2002 a copy of which is located on our website (www.darwinport.nt.gov.au)

Prices are GST inclusive.

DPC Charges Amended 01 July, 2003

D:\Documents and Settings\tc6\Local Settings\Temporary Internet Files\OLKCB\DPC - Mooring Basin Charges Feb 2009.doc

DARWIN PORT CORPORATION	Issue Status	Issue 2
	Issue Date	1 July, 2003
	Authorisation	W. Bruce Wilson
	Page No.	4

Cyclonic Conditions - One Empty Berth.....	13
Cyclonic Conditions - Three or more Empty Berths	15
Normal Condition.....	11
Storm, Cyclonic Conditions.....	12
Mooring Procedures	10
P	
Payment Procedures	8
R	
Rental Advise	9
Rubbish Removal & Waste Oil Disposal	16
S	
Storage	18
Sub-Leasing of Berths	16
U	
Use of Jetties	17
Use of the Service Wharf	17
W	
Wharf & Jetty Load Restrictions	17



Conditions of credit are explained in the Darwin Port Corporation Credit / Debt Management Plan Oct 2002 a copy of which is located on our website (www.darwinport.nt.gov.au)

Prices are GST inclusive.

DPC Charges Amended 01 July, 2003

D:\Documents and Settings\tc6\Local Settings\Temporary Internet Files\OLKCB\DPC - Mooring Basin Charges Feb 2009.doc

DARWIN PORT CORPORATION	Issue Status	Issue 2
	Issue Date	1 July, 2003
	Authorisation	W. Bruce Wilson
	Page No.	5

PLEASE NOTE – A LISTING OF PORT CHARGES MAY BE FOUND ON OUR WEB SITE

www.darwinport.nt.gov.au

Welcome to the Darwin Fishing Harbour Mooring Basin.

This Basin was built with Northern Territory taxpayers' money to provide tidal free moorings for fishing vessels in Darwin where they could be serviced, maintained and supplied by Darwin based companies.

The Basin is operated by the Darwin Port Corporation (DPC) and the Darwin Port Corporation By Laws apply.

As a user of the Basin, you need to familiarise yourself with its features, its operation and the rules that apply within it.

The rules that cover the Basin are based largely on common sense and good neighbourliness, with the aim that all users benefit from their time here and are encouraged to return.

If you need more information or clarification of any item, in the first instance contact the Fishing Harbour Officer on (08) 89993971/8999 3970 or call at the Port Corporation Office at Fishermen's Wharf.

BASIN OPERATING POLICY

These policies were prepared and presented at an Industry Consultation and Planning Meeting held in June 1986. They were modified following the June/July 1987 closure and subsequently reviewed and modified for pleasurecraft owners on 1 October 1990.

In summary the key points are:

- Operation of the Basin is combined with the Fishermen's Wharf
- There is a total manning of two DPC staff
- Polluting or fouling the Basin is prohibited and may lead to the eviction of offenders (see Section 2)
- Normally tidal lock access hours are 0730 - 1545 weekdays only (see Section 3)
- Security is limited to fencing and floodlights around the area.
- Maintenance is carried out by DPC staff
- Consumables, ie electricity/equipment hire are extra costs



- 5 -

Conditions of credit are explained in the Darwin Port Corporation Credit / Debt Management Plan Oct 2002 a copy of which is located on our website (www.darwinport.nt.gov.au)

Prices are GST inclusive.

DPC Charges Amended 01 July, 2003

D:\Documents and Settings\tc6\Local Settings\Temporary Internet Files\OLKCB\DPC - Mooring Basin Charges Feb 2009.doc

DARWIN PORT CORPORATION	Issue Status	Issue 2
	Issue Date	1 July, 2003
	Authorisation	W. Bruce Wilson
	Page No.	6

No long period obstruction of the wharf, jetties or internal roads is permissible, ie no vehicles or gear should be left alongside vessels as the service wharf is intended for maintenance only

As Darwin may be affected by wet season cyclonic conditions, special mooring procedures may apply (see Section 5)

Payment procedures are outlined in Section 4

FOULING OF THE BASIN

An important feature of the Basin's operation is the prevention of any form of pollution or fouling of the water in the Basin or lock.

Design limitations restrict the rise and fall of the water level to less than one metre, which results in almost no changing of the locked-in water in the Basin. There is no tidal flushing.

Boat owners, skippers, persons in charge of vessels, contractors and all persons working on any vessel must be made aware of this situation and advised of their responsibility in ensuring that no pollution or fouling of the Basin occurs in respect of their vessel or group of vessels.

No vessels are allowed to load fuel whilst in the Basin.

Pollution or fouling can occur in many ways. In addition to the waste from vessels, it could be caused by the discharge of oil or oil and water mixtures, the dumping of paint, chemical solvents or other similar chemicals.

The use of vessels' toilets, washrooms, kitchen galleys, washing machines or other similar facilities which discharge overboard and the dumping of rubbish into the Basin or lock are prohibited.

Arrangements may be made to seal all such outlets while a vessel is in the Basin.

For your stay in the Basin to be comfortable, it is essential that the Basin is kept clean.

FOULING OF THE BASIN IS SERIOUS AND MAY LEAD TO PROSECUTION AND EVICTION OF OFFENDERS.



DARWIN PORT CORPORATION	Issue Status	Issue 2
	Issue Date	1 July, 2003
	Authorisation	W. Bruce Wilson
	Page No.	7

LOCK OPERATING PROCEDURES

Lock Hours

Generally, the lock is manned and operated within normal working hours:

Monday to Friday between 07:30 and 15:45

(Lock operation must be completed by 15:45)

Movements through the lock during the above hours are free of charge. Outside of these hours penalty charges apply for the operation of the lock and under some conditions, these charges may be shared:

After hours charges will incur a charge of \$135.96

At the start of the Fishing Closure Season, for four days prior to and ten days after the declared start, the lock will be operational and manned at no extra charge, as and when the tide allows (fishing vessels only).

At the end of the Fishing Closure Season, for ten days prior to and four days after the declared closure, the lock will be operational and manned at no extra charge, as and when the tide allows (fishing vessels only).

Lock Operations

The lock is operated by a DPC employee. Control of the lock gates and the water level is carried out from a semi-automatic console which will allow entry to and exit from the mooring basin within an outside tidal range of 3.2 to 7.5 metres. The minimum depth of water inside the Basin is 3.5m

The design of the lock does not allow both gates to be open simultaneously. Therefore convoy entry or exit is not possible. Vessels exceeding 36m cannot pass through lock.

Waiting berths are provided both inside and outside the lock with entry to the lock controlled by radio and loud hailer. As the lock is 36m long and 15m wide, it is possible on occasions to deal with more than one vessel at a time.

**FOR LOCK OPERATION, CONTACT THE FISHING HARBOUR OFFICER ON
(08) 89993971 OR (08) 89993970**



- 7 -

Conditions of credit are explained in the Darwin Port Corporation Credit / Debt Management Plan Oct 2002 a copy of which is located on our website (www.darwinport.nt.gov.au)

Prices are GST inclusive.

DPC Charges Amended 01 July, 2003

D:\Documents and Settings\tc6\Local Settings\Temporary Internet Files\OLKCB\DPC - Mooring Basin Charges Feb 2009.doc

DARWIN PORT CORPORATION	Issue Status	Issue 2
	Issue Date	1 July, 2003
	Authorisation	W. Bruce Wilson
	Page No.	8

or call at the DPC Office at Fishermen's Wharf or radio on Channel 6 VHF - call sign Norport 25.

PAYMENT PROCEDURES

All berth allocations must be paid for, prior to entry, at either the Fishermen's Wharf Office or the Port Authority's Wharf Office, Operations Division, East Arm Wharf.

The attention of hirers is drawn to the basic conditions, especially fouling, non-payment of fees and observance of conditions generally.

Hirers must provide:

Name/s and details of vessel/s using the berth
Names and telephone numbers of two contact persons (for emergencies)
Details of length of hire period.

Additionally, pleasure vessels using the Basin will have to provide proof of size of beam. If no documentation is available, the beam will be measured by a Port Corporation Official.

Trading terms are as per the Darwin Port Corporation Credit / Debt Management Plan Oct 2002 a copy of which is located on our website (www.darwinport.nt.gov.au)

Please note invoices will not be issued for interest charges as they will appear on your statement.

Fishing and Commercial Vessels

The rates for berth hire for fishing and commercial vessels only are as follows:

	20m Pen	25m Pen	30m Pen
Annual Rental (paid quarterly)	\$3,071.50	\$3,930.58	\$4,668.06
Daily Rate (closure)	\$25.89	\$31.53	\$38.29
Daily Rate (fishing)	\$11.26	\$15.76	\$18.01

The renewal date for annual rentals will be 12 months from date of first payment.



DARWIN PORT CORPORATION	Issue Status	Issue 2
	Issue Date	1 July, 2003
	Authorisation	W. Bruce Wilson
	Page No.	9

Please Note: ALL RENTAL PAYMENTS SHOULD BE MADE IN ADVANCE - If payments for annual berths fall into arrears then the daily rate will be charged. (PLUS INTEREST - CHECK WITH CHERYL)

DAILY SURCHARGE RATES

These rates are payable in addition to the chosen period rental charge and are applicable during the two closure periods of the fishing industry season (approximately November to April and June to July of each year - the actual dates are not publicised until approximately a month or so beforehand). The attached tables show the daily rates applicable during these periods.

PLEASE NOTE:

ALL RENTALS MUST BE PAID IN ADVANCE.

VESSELS VACATING A BERTH PRIOR TO THE EXPIRATION OF THEIR RENTAL PERIOD WILL HAVE THEIR RENTAL PERIOD RECALCULATED AT A DAILY RATE.

ATTACHMENT A

DARWIN FISHING HARBOUR MOORING BASIN

DAILY RENTAL CHARGES FOR PLEASURE CRAFT - Effective 1 July 2003

Beam (m)	Non Closure\$	#Daily Surcharges\$	Beam (m)	Non Closure\$	Beam Surcharges\$
2	\$13.51	\$6.76	6	\$39.41	\$19.14
2.1	\$13.51	\$6.76	6.1	\$39.41	\$19.14
2.2	\$14.64	\$6.76	6.2	\$40.53	\$19.14
2.3	\$14.64	\$6.76	6.3	\$40.53	\$20.27
2.4	\$15.76	\$7.88	6.4	\$41.65	\$20.27
2.5	\$15.76	\$7.88	6.6	\$42.79	\$20.27
2.6	\$16.89	\$7.88	6.6	\$42.79	\$20.27



Conditions of credit are explained in the Darwin Port Corporation Credit / Debt Management Plan Oct 2002 a copy of which is located on our website (www.darwinport.nt.gov.au)

Prices are GST inclusive.

DPC Charges Amended 01 July, 2003

D:\Documents and Settings\tc6\Local Settings\Temporary Internet Files\OLKCB\DPC - Mooring Basin Charges Feb 2009.doc

DARWIN PORT CORPORATION	Issue Status	Issue 2
	Issue Date	1 July, 2003
	Authorisation	W. Bruce Wilson
	Page No.	10

2.7	\$18.01	\$9.00	6.7	\$43.91	\$21.39
2.8	\$18.01	\$9.00	6.8	\$43.91	\$21.39
2.9	\$19.14	\$9.00	6.9	\$45.03	\$21.39
3	\$19.14	\$9.00	7	\$45.03	\$22.52
3.1	\$20.27	\$10.14	7.1	\$46.16	\$22.52
3.2	\$20.27	\$10.14	7.2	\$47.29	\$22.52
3.3	\$21.39	\$10.14	7.3	\$47.29	\$22.52
3.4	\$22.52	\$11.26	7.4	\$48.41	\$23.64
3.5	\$22.52	\$11.26	7.5	\$48.41	\$23.64
3.6	\$23.64	\$11.26	7.6	\$49.54	\$23.64
3.7	\$23.64	\$11.26	7.7	\$49.54	\$24.77
3.8	\$24.77	\$12.38	7.8	\$50.67	\$24.77
3.9	\$25.89	\$12.38	7.9	\$51.79	\$24.77
4	\$25.89	\$12.38	8	\$51.79	\$24.77
4.1	\$27.02	\$12.38	8.1	\$52.92	\$25.89
4.2	\$27.02	\$13.51	8.2	\$52.92	\$25.89
4.3	\$28.15	\$13.51	8.3	\$54.04	\$25.89
4.4	\$28.15	\$13.51	8.4	\$54.04	\$27.02
4.5	\$29.27	\$14.64	8.5	\$55.17	\$27.02
4.6	\$30.40	\$14.64	8.6	\$56.30	\$27.02
4.7	\$30.40	\$14.64	8.7	\$56.30	\$27.02
4.8	\$31.53	\$14.64	8.8	\$57.42	\$28.15
4.9	\$31.53	\$15.76	8.9	\$57.42	\$28.15
5	\$32.65	\$15.76	9	\$58.55	\$28.15
5.1	\$32.65	\$15.76	9.1	\$59.67	\$28.15
5.2	\$33.77	\$16.89	9.2	\$59.67	\$29.27
5.3	\$34.91	\$16.89	9.3	\$60.80	\$29.27
5.4	\$34.91	\$16.89	9.4	\$60.80	\$29.27
5.5	\$36.03	\$16.89	9.5	\$61.92	\$30.40
5.6	\$36.03	\$18.01	9.6	\$61.92	\$30.40
5.7	\$37.15	\$18.01	9.7	\$63.05	\$30.40
5.8	\$37.15	\$18.01	9.8	\$64.18	\$30.40
5.9	\$38.29	\$19.14	9.9	\$64.18	\$31.53
			10	\$65.30	\$31.53



Conditions of credit are explained in the Darwin Port Corporation Credit / Debt Management Plan Oct 2002 a copy of which is located on our website (www.darwinport.nt.gov.au)

Prices are GST inclusive.

DPC Charges Amended 01 July, 2003

D:\Documents and Settings\tc6\Local Settings\Temporary Internet Files\OLKCB\DPC - Mooring Basin Charges Feb 2009.doc

DARWIN PORT CORPORATION	Issue Status	Issue 2
	Issue Date	1 July, 2003
	Authorisation	W. Bruce Wilson
	Page No.	11

MOORING PROCEDURES

During a cyclone warning the Harbourmaster or his representative will inspect each vessel's moorings. His instructions must be adhered to.

Masters must remain aboard their vessels until the moorings have been inspected and the Harbourmaster or his representative is satisfied the vessels can be left unmanned.

MOORING PATTERNS

Normal Condition

A maximum wind speed of 36m/sec or 70 knots has been assumed for a Normal Condition. For this wind condition a three line mooring pattern as shown below may be adopted.

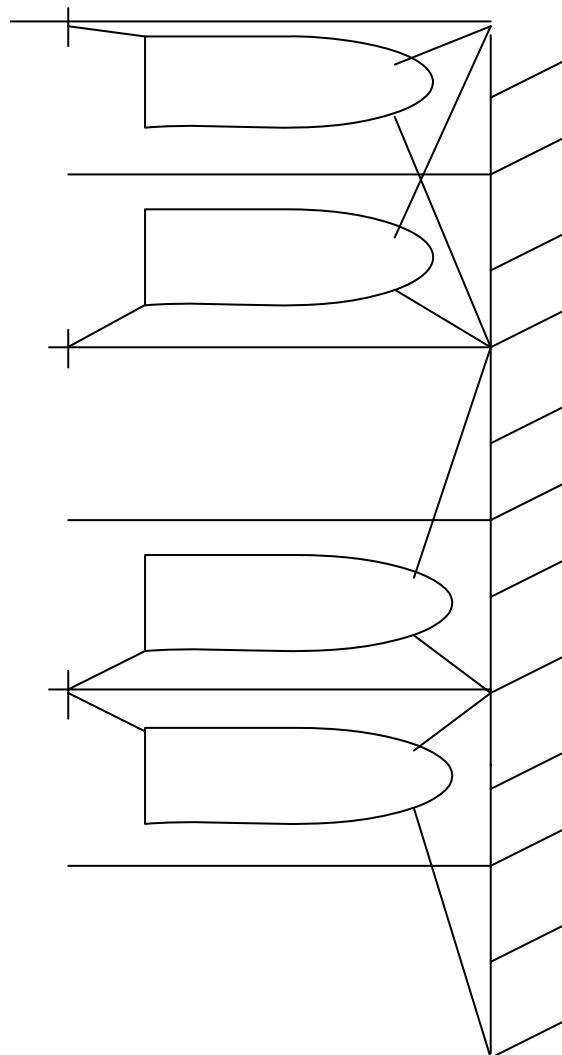

DARWIN PORT CORPORATION	Issue Status	Issue 2
	Issue Date	1 July, 2003
	Authorisation	W. Bruce Wilson
	Page No.	12

Storm, Cyclonic Condition

When the wind speed exceeds 36m/sec or 70 knots, the mooring arrangement of the vessels must be changed to not less than a four line mooring system as shown below.

Full Occupancy - Cyclonic Conditions

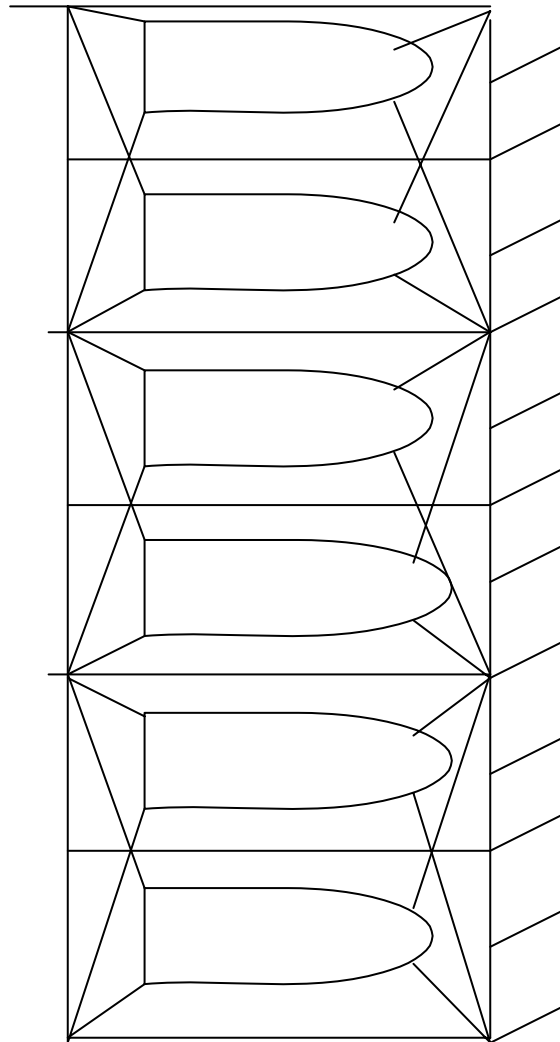

DARWIN PORT CORPORATION	Issue Status	Issue 2
	Issue Date	1 July, 2003
	Authorisation	W. Bruce Wilson
	Page No.	13

One Empty Berth - Cyclonic Conditions

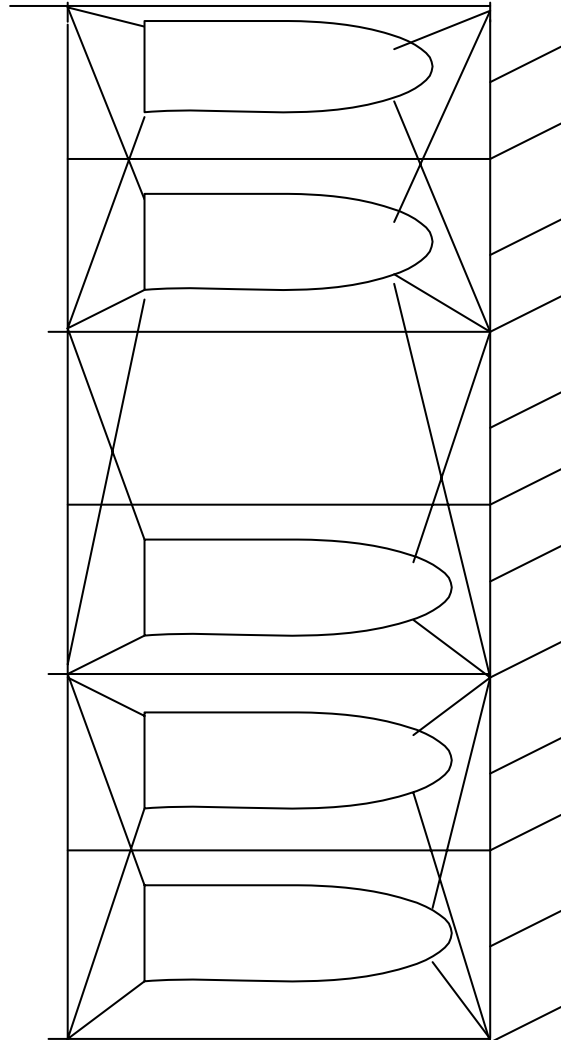

Conditions of credit are explained in the Darwin Port Corporation Credit / Debt Management Plan Oct 2002 a copy of which is located on our website (www.darwinport.nt.gov.au)

Prices are GST inclusive.

DPC Charges Amended 01 July, 2003

D:\Documents and Settings\tc6\Local Settings\Temporary Internet Files\OLKCB\DPC - Mooring Basin Charges Feb 2009.doc

DARWIN PORT CORPORATION	Issue Status	Issue 2
	Issue Date	1 July, 2003
	Authorisation	W. Bruce Wilson
	Page No.	14

Two **Empty Berths** - Cyclonic Conditions

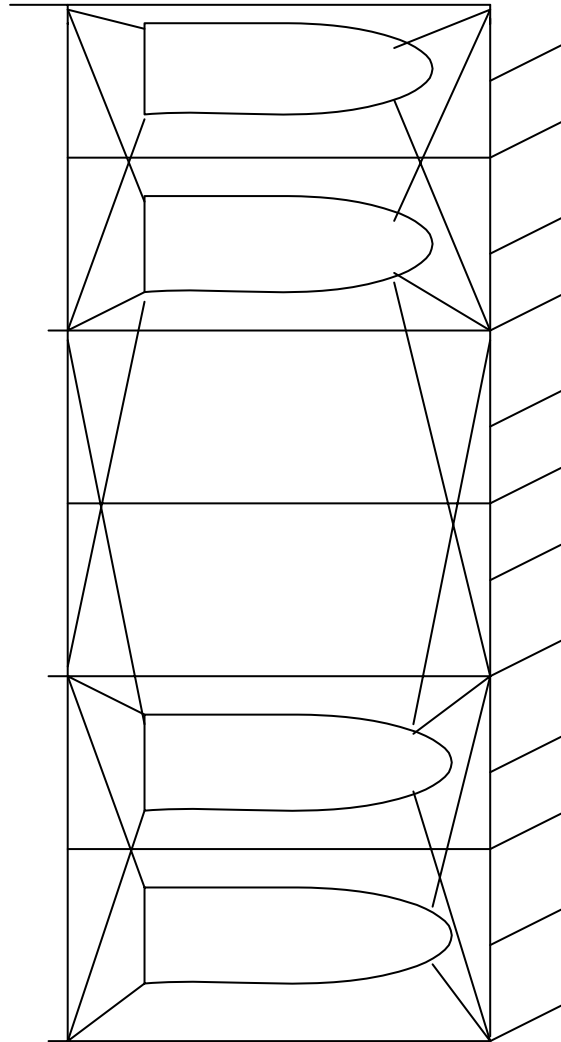

Conditions of credit are explained in the Darwin Port Corporation Credit / Debt Management Plan Oct 2002 a copy of which is located on our website (www.darwinport.nt.gov.au)

Prices are GST inclusive.

DPC Charges Amended 01 July, 2003

D:\Documents and Settings\tc6\Local Settings\Temporary Internet Files\OLKCB\DPC - Mooring Basin Charges Feb 2009.doc

DARWIN PORT CORPORATION	Issue Status	Issue 2
	Issue Date	1 July, 2003
	Authorisation	W. Bruce Wilson
	Page No.	15

Three or More **Empty Berths** - Cyclonic Conditions

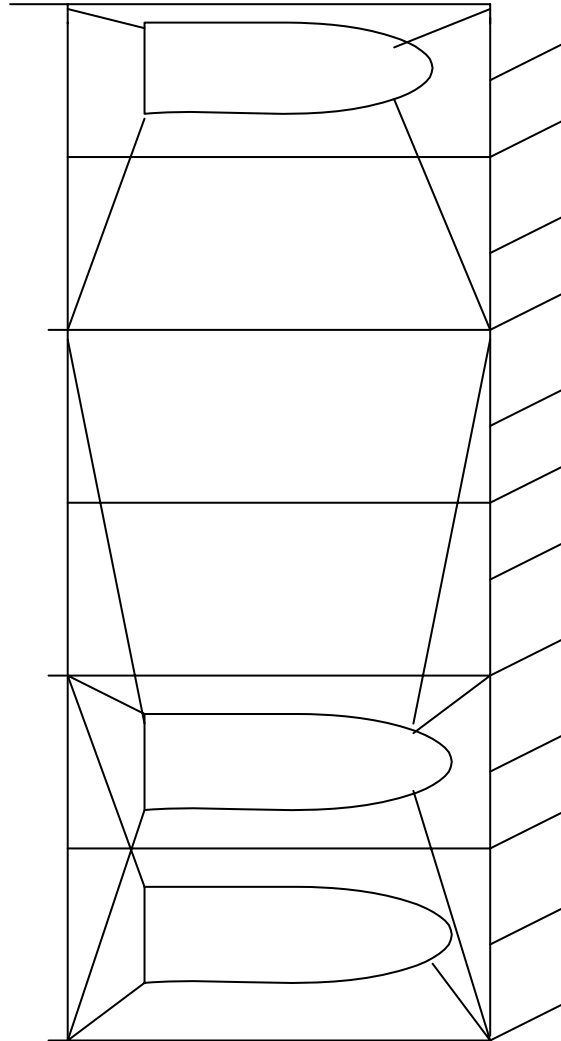

Conditions of credit are explained in the Darwin Port Corporation Credit / Debt Management Plan Oct 2002 a copy of which is located on our website (www.darwinport.nt.gov.au)

Prices are GST inclusive.

DPC Charges Amended 01 July, 2003

D:\Documents and Settings\tc6\Local Settings\Temporary Internet Files\OLKCB\DPC - Mooring Basin Charges Feb 2009.doc

DARWIN PORT CORPORATION	Issue Status	Issue 2
	Issue Date	1 July, 2003
	Authorisation	W. Bruce Wilson
	Page No.	16

GENERAL INFORMATION

Company hire of Berths & Nominated Vessels

A list of nominated vessels expected to utilise berths must be supplied with the company's application for a berth. Unlisted vessels will not be permitted entry to the Basin.

Sub-Leasing of Berths

Vessels may not sub-lease their berths to other vessels.

The Port Corporation may sub-lease berths when there is a need and wherer the lessor of the berth consents. The revenue from such sub-lease arrangements is shared equally between the original lessor and the Corporation.

Additional Vessels in Berths

During the 'Dry' season if space is at a premium additional vessels may, with DPC permission, share a berth. In this situation each vessel will be charged for a berth.

Caretaker Tenancy

Limited occupancy is allowed provided no wastes are discharged into the Basin. Because of the still water in the Basin it is relatively easy to identify offenders. Once identified, an offender may be prosecuted, could have their vessel removed from the Basin and be held responsible for all costs involved in clean-up operations.

Rubbish Removal & Waste Oil Disposal

All rubbish should be disposed of in the bins provided which are removed regularly by DPC staff. Any rubbish left lying around could have their vessel removed from the Basin and be held responsible for all costs involved in clean-up operations.

Waste oil must be disposed of in an acceptable manner and on no account must any be placed in bins, open topped containers or discharged into the Basin. Vacuum suction tankers are available to remove oil.



DARWIN PORT CORPORATION	Issue Status	Issue 2
	Issue Date	1 July, 2003
	Authorisation	W. Bruce Wilson
	Page No.	17

Wharf & Jetty Load Restrictions

Service wharf hard-stand areas, all finger jetties and wharf areas within the Basin are capable of holding a 30 tonne capacity crane.

Use of Jetties

Vehicular use of the three jetties must be kept to an absolute minimum, otherwise access to the seaward berths would become impossible. Users are requested to use their common sense and co-operate with others.

PLEASE NOTE: Dinghies etc should not be moored under the finger jetties as they can damage the water pipes underneath.

Use of the Service Wharf

The 100 metre service wharf at the southern end of the Basin is available for vessels requiring to come alongside to unload or load equipment catch etc. Vessels should vacate this wharf when their operations are completed.

If you wish to use this wharf please contact the DPC office at Fishermen's Wharf (VHF Channel 6) for berth allocation.

Facilities

Telephone, showers, toilets and parking areas are available for Basin users. Locations are marked on map on page 18 and 19.

Electricity and water supplies are also available and connections may be arranged at the DPC Office. Electricity charges are invoiced monthly and are at the current schedule rate. Should a DPA electrician be called out to a fault which is subsequently found to be caused by a failure of a vessel's equipment, the costs involved, including labour, will be charged to the vessel.

Parking is allowed at the owners risk in designated parking areas only.

Security is restricted to provision of fences and floodlights.

Equipment Hire



DARWIN PORT CORPORATION	Issue Status	Issue 2
	Issue Date	1 July, 2003
	Authorisation	W. Bruce Wilson
	Page No.	18

There is a various range of equipment available for hire from the Darwin Port Corporation. All bookings for mechanical equipment should be made through the DPC. Details of these and charges may be obtained the DPC Office, Fishermen's Wharf or telephone 89993977.

Storage

No storage of equipment, dinghies etc are allowed on the roads, garden areas or adjacent spaced.



DARWIN PORT CORPORATION	Issue Status	Issue 2
	Issue Date	1 July, 2003
	Authorisation	W. Bruce Wilson
	Page No.	19

**DARWIN PORT CORPORATION
GPO Box 390**

**Darwin NT 0801
Australia**

**Head Office: Darwin Business Park
Export Drive, Berrimah
Telephone: (08) 8922 0660
Facsimile: (08) 8922 0666**

FORT HILL WHARF DUTY OFFICER

**(After Hours): (08) 8999 3974
Mobile: 0401 117 057
Facsimile: (08) 8941 0709**

**OPERATIONS OFFICE
EAST ARM / FORT HILL WHARF**

**Telephone: (08) 8922 0607
Facsimile: (08) 8941 2039**

HARBOURMASTER

**Telephone: (08) 8922 0677
Mobile: 0419840041
Facsimile: (08) 8947 5276**

EAST ARM PORT DUTY OFFICER

**Telephone: (08) 8922 0675
Mobile: 0401 117 090
Facsimile: (08) 8947 5274**

